

INTERNATIONAL BOXING ASSOCIATION

Technical & Competition Rules

Effective from January 30, 2010



TABLE OF CONTENTS

DEFINITIONS	3
RULES FOR COMPETITION MANAGEMENT	4
Rule 1. Classification of boxers	4
Rule 2. Eligibility of boxers	5
Rule 3. Registration of boxers for competitions	7
Rule 4. Medical examination	7
Rule 5. Weigh-in	8
Rule 6. Substitution of boxers on general weigh-in	9
Rule 7. The official Draw	9
Rule 8. Duration and number of rounds	10
Rule 9. The decisions	10
Rule 10. AIBA scoring system	12
Rule 11. Scoring points	13
Rule 12. Fouls	13
Rule 13. Boxer down	14
Rule 14. AIBA competition approval	16
Rule 15. Competition venue	16
Rule 16. AIBA anti-doping regulations	16
RULES FOR COMPETITION OFFICIALS	17
Rule 1. Technical Delegate (TD)	17
Rule 2. Deputy Technical Delegate	17
Rule 3. Competition Manager (CM)	18
Rule 4. International Technical Official (ITO)	18
Rule 5. Competition Jury	19
Rule 6. Rules for Both Referees & Judges	20
Rule 7. Referees	21
Rule 8. Judges	23
Rule 9. AIBA Referees & Judges Management	23
Rule 10. Coaches	23
Rule 11. Seconds	24
Rule 12. Medical Jury	24
Rule 13. Timekeeper	26
Rule 14. Official Announcer	27
RULES FOR COMPETITION EQUIPMENT	28
Rule 1. The Ring and Accessories	28
Rule 2. Boxing gloves	28
Rule 3. Headguards	28
Rule 4. Bandages	29
Rule 5. Gumshield	29
Rule 6. Protectors	29
Rule 7. Competition uniform	30
Rule 8. AIBA Scoring System Equipment	30
APPENDIX A: Duties of Technical Delegate & Competition Manager	31
APPENDIX B: AIBA Code of Conduct	33
APPENDIX C: Approved Event Guideline	34
APPENDIX D: World Ranking Guideline	36
APPENDIX E: Seeding Procedure of the Draw Ceremony	37
APPENDIX F: Boxer's Uniform Guidelines	43
APPENDIX G: AIBA Referees & Judges Management System	46
APPENDIX H: Ring Specifications and Guidelines	54
APPENDIX I: Field of Play	57
APPENDIX J: Gloves and Headguard Specifications and Guidelines	59
APPENDIX K: Terminology for Weight Categories and Weight Range	62

DEFINITIONS

“**AIBA**” means the International Boxing Association;

“**AIBA Controlled Events**” means AIBA Approved Events solely managed by AIBA as described in Appendix C;

“**AIBA Approved Events**” means boxing competitions which are approved and/or endorsed by AIBA. AIBA allows the use of its logo and provides AIBA officials to manage these events as described in Appendix C;

“**Bout**” means a boxing match;

“**Confederation**” means a group of National Federations recognized by AIBA that belong to the same continent;

“**Daily Weigh-In**” means that each entered Boxer is required to weigh-in each day on which this Boxer is due to box to ensure that the actual weight on that day does not exceed the maximum of the Boxer’s registered weight class;

“**Delegation**” means participating team members including Boxers, coaches, team doctors and team managers in boxing competitions;

“**Draw Commission**” means a group of minimum two persons who will draw the R&Js in each bout in any AIBA competition;

“**Dual Match**” means a competition featuring Boxers from two countries only;

“**Field Of Play (FOP)**” means the competition area which extends for at least 6 meters outside the platform of the ring;

“**Gloves**” means a piece of clothing that you wear on your hands in order to protect them during the competition;

“**ITO**” means the International Technical Official appointed by AIBA excluding R&Js such as Competition Jury, Draw Commission and Medical Jury members, R&J Coordinator and Equipment Manager;

“**Judge**” means someone who allocates points during a bout based on each Boxer’s performance on the ring in respect of AIBA Technical & Competition Rules;

“**National Federation**” is any boxing federation or association that is admitted into membership of AIBA by the Congress, hence, becoming a Member of AIBA;

“**Official Draw**” means the ceremony to draw the Boxers to decide the bout schedules in each weight category;

“**Participating Boxer**” means any Boxer licensed by a National Federation that is a Member of AIBA;

“**Referee**” means someone who makes sure that the AIBA Technical & Competition Rules are followed by the Boxers during their bout;

“**Team Officials**” mean the team managers, coaches and doctors of a team entered by a National Federation in boxing competitions excluding Boxers;

“**Technical Delegate**” means a person who is appointed by AIBA or Confederation to be responsible for all technical related issues in boxing competitions;

COMPLIANCE OF THE RULES

These AIBA Technical & Competition Rules are the ones which worldwide AIBA boxing members and family must follow and respect in any of their competitions and activities at all levels.

RULES FOR COMPETITION MANAGEMENT

RULE 1. CLASSIFICATION OF BOXERS

1.1. Age Classification:

- 1.1.1. Men and Women Boxers between the ages of 19 - 34 are categorized as Elite Boxers.
- 1.1.2. Boy and Girl Boxers between the ages of 17 to 18 are categorized as Youth Boxers.
 - 1.1.2.1. Youth Boxers are permitted to participate in Elite competitions as per rules applicable to Elite Boxers.
- 1.1.3. Boy and Girl boxers between the age of 15 to 16 are categorized as Junior boxers.
- 1.1.4. The age of a boxer is determined using his/ her year of birth.
- 1.1.5. All competitions related to school boys and girls and all other younger age Boxers are managed by only National Federations and at Confederation levels. The age of the Boxers shall not be over 14 years old. The range of the ages of the Boxers participating in these competitions shall not be more than 2 years.

1.2. Weight Classifications¹:

- 1.2.1. For Elite Men and Youth Boy Boxers
 - 1.2.1.1. 11 Weight Categories as follow:
48 kg, 51 kg, 54 kg, 57 kg, 60 kg, 64 kg, 69 kg, 75 kg, 81 kg, 91 kg, 91+ kg
 - 1.2.1.2. Effective from September 1, 2010: 10 Weight Categories as follow:
46 kg - 49 kg, 52 kg, 56 kg, 60 kg, 64 kg, 69 kg, 75 kg, 81 kg, 91 kg, 91+ kg
- 1.2.2. For Elite Women and Youth Girls Boxers:
 - 1.2.2.1. 11 Weight Categories as follow:
46 kg, 48 kg, 51 kg, 54 kg, 57 kg, 60 kg, 64 kg, 69 kg, 75 kg, 81 kg, 81+ kg
 - 1.2.2.2. Effective from September 1, 2010: 10 Weight Categories as follow:
45 kg - 48 kg, 51 kg, 54 kg, 57 kg, 60 kg, 64 kg, 69 kg, 75 kg, 81 kg, 81+ kg
 - 1.2.2.3. For Elite Women 3 Weight Categories for the Olympic Games shall apply as follow:
48 kg to 51 kg, 57 kg to 60 kg, 69 kg to 75 kg
- 1.2.3. For Junior Boys and Junior Girls Boxers:
 - 1.2.3.1. 13 weight categories as follow:
46 kg, 48 kg, 50 kg, 52 kg, 54 kg, 57 kg, 60 kg, 63 kg, 66 kg, 70 kg, 75 kg, 80 kg and 80+kg.

¹Terminologies for each weight category can be found in Appendix K.

RULE 2. ELIGIBILITY OF BOXERS

2.1. Nationality

- 2.1.1. Any Boxer participating in AIBA Approved Events must be a national of the country of the AIBA National Federations participating in such competitions.
- 2.1.2. For all disputes taking place during World Championships, World Cup and other AIBA approved international level events, the final decision on determining the nationality lies with the AIBA Executive Committee.
- 2.1.3. For all disputes taking place during Continental Championships and other AIBA Confederation approved continental level events, the final decision on determining the nationality lies with the Continental Confederation Executive Committee in accordance with AIBA Technical & Competition Rules.
- 2.1.4. If a Boxer wishes to change nationality, this Boxer can enter any of AIBA Approved Events as a participant of the changed National Federation after 3 (three) years from the change of nationality.
- 2.1.5. If a Boxer, after having represented one National Federation in any AIBA Approved Events, is also a national of two or more countries at the same time, this Boxer shall select only one National Federation to enter AIBA Approved Events. In this case, once the Boxer selects one National Federation, this Boxer shall not enter any AIBA Approved Events with changed National Federation team for 3 (three) years.
- 2.1.6. For the determination of the 3 (three) years period, AIBA shall develop a database of all Boxers to trace their competition records. Any Host Federation and Organizing Committee should be able to send the final entries to AIBA in order to receive a confirmation on the nationality and eligibility status of any Boxer prior to the competition. However, until the database is completed, the nationality shall be checked through the passport, Boxer's record book and/or membership card and any previous AIBA Approved Event results.
- 2.1.7. Prior to the competition, the AIBA HQs Office shall confirm the nationality and eligibility of the Boxer. However, during the competition, any disputes will be resolved by the Technical Delegate and then will be ratified by the AIBA HQs Office.

2.2. One Entry per Weight Category

- 2.2.1. For all AIBA Controlled Events such as World Championships, World Cup, Continental Championships and Olympic Qualifying Tournaments, only one Boxer per weight category per country shall be allowed to compete.
- 2.2.2. For all other events, the Host Federation and/or the Organizing Committee may allow more than one Boxer per weight category per country.

2.3. Medical Aspect of Qualification for Boxers

2.3.1. Medical Certification:

- 2.3.1.1. A competitor shall not be allowed to compete in an international competition unless this Boxer possesses an International Competition Record Book in which this Boxer must be certified as fit to box by a qualified Doctor of Medicine approved by the presiding AIBA Medical Jury member. The International Competition Record Book is valid if it is completely filled in and up to date and the annual medical examination is not older than one year.

- 2.3.1.2. On each day the Boxer will be required to box, the competitor shall be certified as fit to compete by a qualified Doctor of Medicine who shall be approved by the National Federation under whose jurisdiction the competition is taking place, or during the Olympic Games, World Championships, World Cup and AIBA Challenge Matches, by AIBA Medical Commission.
- 2.3.2. Boxer with Allowed Handicap
 - 2.3.2.1. Refer to current Medical Handbook for allowed Handicap.
- 2.3.3. Prohibited Conditions - The boxers with the following prohibited conditions are not allowed to enter any of AIBA Approved Events:
 - 2.3.3.1. If a Boxer wears a dressing on a cut, wound abrasion, laceration or blood swelling on their scalp or face including the nose and ears. For the case of a Boxer with abrasion or laceration, no dressing other than Collodion or Steri-Strip is allowed. The decision should be made by the Doctor examining the Boxer on the day the Boxer is competing.
 - 2.3.3.2. A Boxer shall be clean-shaved before all medical examination. Beards and moustaches are not allowed. No type of body piercing and no body accessories are allowed to be worn during a bout.
 - 2.3.3.3. In all AIBA Approved Events, pregnant Boxers are not allowed to participate in any competition and must sign a declaration of non pregnancy and/or present a medical certification before the medical check.
- 2.3.4. Medical Certification following Probation Periods - Before resuming boxing after any of the periods of rest prescribed in the three rules 2.3.6.1, 2.3.6.2, 2.3.6.3, a Boxer must be certified by the Boxer's physician to take part in competitive boxing.
- 2.3.5. Referee Stop Contest - Head blow (RSCH) - The Referee will indicate to the Jury members and Judges to annotate the score with "RSCH" when the Referee has stopped the contest as a result of a Boxer being unable to continue due to blows to the head. 'RSCH' is a term to be used only when a Boxer is being saved from a knock-out after having received hard head blows making the Boxer defenseless and incapable of continuing. (The term RSCH is not to be used when a Boxer is simply outclassed and is receiving too many scoring hits without scoring).
- 2.3.6. Protective Sanitary Measures
 - 2.3.6.1. One knock-out or RSCH - A Boxer who has been knocked out with no loss of consciousness as a result of head blows during a contest or wherein the Referee has stopped the contest due to the Boxer having received hard blows to the head making this Boxer defenseless or incapable of continuing, shall not be permitted to take part in competitive boxing or sparring for a period of at least 30 days after the Boxer has been knocked out or given an RSCH decision.
 - 2.3.6.2. Two knock-outs or two RSCH - A Boxer who has been knocked out as a result of head blows during a contest or wherein the Referee has stopped the contest due to a Boxer having received hard blows to the head making this Boxer defenseless or incapable of continuing twice in a period of 90 days, shall not be permitted to take part in competitive boxing or sparring during a period of 90 days from the second knock-out or RSCH.
 - 2.3.6.3. Three knock-outs or three RSCH - A Boxer who has been knocked out as a result of a head blow(s) during a contest or wherein the Referee has stopped the contest due to the Boxer having received hard blows to the head making this Boxer defenseless or incapable of continuing three times in a period of 12 months, shall not be allowed to take part in competitive boxing or sparring for a period of 360 days from the third knock-out or RSCH.

- 2.3.6.4. Each knock-out suffered as a result of a head blow(s) and each RSCH must be recorded by the Medical Jury in the Boxer's International Competition Record Book.
- 2.3.6.5. All protective measures should also apply if a knock-out and or concussion occurs during training or anywhere else. The coach shall be responsible to report to the National Federation.
- 2.3.6.6. If one Boxer is knocked-out by a blow after "break" or "stop" and is counted "out", the win by "disqualification" does not permit this Boxer to continue boxing in the competition.
- 2.3.6.7. Injured Boxers may be restricted from boxing at the discretion of the AIBA Medical Jury.
- 2.3.6.8. Boxers returning from RSCH – Knock-out injury must receive clearance in writing from their physician and inform the AIBA HQs Office before returning to box.

2.4. WSB Boxers in AIBA Competitions

- 2.4.1. Once an AIBA Boxer turns to Professional boxing, this boxer shall not be allowed to compete in AIBA competitions at any levels.
- 2.4.2. All WSB Boxers shall be allowed to participate in Olympic Games and Olympic qualifying events in all levels as well as to designated important events.

RULE 3. REGISTRATION OF BOXERS FOR COMPETITIONS

3.1. Validity of Documents

The following are mandatory documents and material that all Boxers entering any of AIBA Approved Events must possess:

- 3.1.1. Passport - The nationality and date of birth of the Boxers will be checked.
- 3.1.2. Boxer Record Book - The authenticity of Boxers' update of medical and membership status will be checked.
- 3.1.3. Accreditation Card - The Boxers should present their registered status in a competition by presenting a valid accreditation card.

RULE 4. MEDICAL EXAMINATION

- 4.1. At the time fixed for the weigh-in, the competitor must be considered as fit to compete and examined by a physician appointed by a member of the Medical Jury before being weighed-in. With a view to ensure a smooth running of the weigh-in, the Technical Delegate may decide to begin the medical examination at an earlier time. The Chairperson of the Medical Jury can select local or team Doctors to assist with the duties of the Medical Jury only for the medical examination in General weigh-in.

- 4.2. At the medical examination and weigh-in, an up-to-date Competition Record Book with correct information must be presented by the Boxer. This Competition Record Book must be signed and/or stamped by the Secretary General or Executive Director of the Boxer's National Federation, where the requisite entries shall be made by the officials in charge. If a Competition Record Book is not presented by the Boxer at the medical examination and weigh-in, this Boxer shall not be allowed to compete.
- 4.3. In addition, a woman Boxer shall answer to the best of her knowledge any questions raised by the Medical Jury and shall present a signed declaration of non-pregnancy in the record book.
- 4.4. Gender Test - For AIBA Approved Events, a gender test can be done.

RULE 5. WEIGH-IN

5.1. In All AIBA Approved Events

- 5.1.1. All entered Boxers must attend the General Weigh-In in the morning of the first competition day, except as described in article 5.1.2.
- 5.1.2. For all AIBA events, when the number of entered Boxers exceeds 300 after the final entry deadline is closed and for the Olympic Games, the General Weigh-In may be organized no more than 24 hours prior to the medical check of the first competition day based on the Technical Delegate's decision.
- 5.1.3. In any case, the time from the end of the General Weigh-In to the start of the first bout should not be less than 6 hours. The time from the end of the Daily Weigh-In to the start of the first bout of the remaining days of competition should not be less than 3 hours.

The Technical Delegate of the event reserves the right to relax this condition, if unavoidable circumstances occur and after consultation with the Chairperson of the Medical Jury.
- 5.1.4. The weigh-in shall be conducted by officials authorized by the Technical Delegate. A team official of the National Federation of the Boxer may be present at the weigh-in; however, and in any circumstances, the team official is not allowed to interfere in the process of weigh-in.
- 5.1.5. On the General Weigh-In, the registered Boxer's weight should not exceed the maximum of the Boxer's weight class nor be below the minimum of the Boxer's weight class. The weight registered at the General Weigh-In on the first day decides the Boxer's weight class for the entire competition, but this Boxer will still be required to weigh-in each day on which this Boxer is due to box to ensure that the actual weight on that day does not exceed the maximum of the Boxer's registered weight class. A contestant may only box in the weight for which this Boxer has qualified during the General Weigh-In.
- 5.1.6. Scale - The weight is the one shown on the scale, the body being naked except for a swimming suit or underwear. When necessary, the Boxer may take off the underwear on the scale only. Electronic scales may be used. Trial scales used at the tournament and official weigh-in scales have to be of the same manufacturer and of the same calibration.
- 5.1.7. The weigh-in must be conducted by officials of the same gender.

RULE 6. SUBSTITUTION OF BOXERS ON GENERAL WEIGH-IN

- 6.1. A competitor will be allowed to be present at the official scales only once at the first medical examination and General Weigh-In. The weight recorded on that presentation is final.
- 6.2. It is permissible, however, for the delegate of the nation of any competitor who has failed to make the weight category at the General Weigh-In to enter this Boxer thereupon for the higher or lower weight category for which this Boxer is qualified if such nation has a free place at that weight category, and the General Weigh-In is not yet closed.
- 6.3. It is also permissible for a nation to substitute one Boxer for another at any time up to the close of the General Weigh-In and the medical examination, provided that in any competition where reserves are permitted, the substitute Boxer has been entered as reserve for that weight category, or any other weight category.
- 6.4. This rule is only applicable for open Championships where reserved Boxers are permitted.
- 6.5. All other cases of substitutions shall be finalized the day before the General Weigh-In.

RULE 7. THE OFFICIAL DRAW

- 7.1. The Official Draw shall take place as soon as possible after the official medical examination and General Weigh-In. It shall be completed no less than three (3) hours prior to the first bout on the first day of the competition.
- 7.2. The Official Draw shall not be held more than 3 hours after the completion of the weigh-in at the exception of rule 7.3., and if the General Weigh-In is organized the morning prior to the first competition day. At least one team official of each participating Delegation must attend the draw.
- 7.3. The Official Draw for the Olympic Games, for the AIBA World Championships and for all AIBA Approved Events, after the final entry deadline is closed, shall be held one day before the competition.
- 7.4. The computerized draw system is to be used in all AIBA Approved Events. In the case the computerized draw system is not working, the manual system can be used. The General Weigh-In and the Official Draw shall be held on the same day.
- 7.5. Byes - In competitions where there are more than four competitors, a sufficient number of byes shall be drawn in the first series to reduce the number of competitors in the second series to 4, 8, 16 or 32. Competitors drawing a bye in the first series shall be the first to box in the second series. If there are an odd number of byes, the Boxer who draws the last bye will compete in the second series against the winner of the first bout in the first series. Where the number of byes is even, the Boxers drawing byes shall box the first bouts in the second series in the order in which they are drawn. No medal shall be awarded to a Boxer who has not boxed at least once.
- 7.6. Bout Schedule - At the Olympic Games, World Championships and Continental Championships, the bout schedule should be arranged in the order of weights so that in each series the lightest weights will be run off first and thereafter in order of weights up to the heaviest weights in that series followed by the lightest weights in the next series, and so on. In arranging the schedule of the finals and semi-finals of Championships, the wishes of the Local Organizing Committee may be accommodated by the Technical Delegate, as long as the results of the draw are not called into question.
- 7.7. Possible Re-Draw - In any case, until the last weight category draw is completed, if there is any mistake or unavoidable circumstance taking place, the Technical Delegate has the right to order the particular weight draw(s) to be done again.
- 7.8. Seeding Procedure - shall respect the seeding procedure of the draw ceremony (i.e. Appendix E) and be in accordance with World ranking guideline (i.e. Appendix D).
- 7.9. The Technical Delegate must ensure, where practicable, that no competitor shall box twice in the competition before all other boxers in the same weight category have boxed at least once. In special situations, the Technical Delegate has the right to relax this rule.

RULE 8. DURATION AND NUMBER OF ROUNDS

- 8.1. In all AIBA events Men Elite and Youth Boys Competitions, the bouts shall consist of three (3) rounds of three (3) minutes each.
- 8.2. In all AIBA events Women Elite and Youth Girls Competitions, the bouts shall consist of four (4) rounds of two (2) minutes each.
- 8.3. In all AIBA events Junior Boys and Girls Competitions, the bouts shall consist of three (3) rounds of two (2) minutes each.
- 8.4. For all above listed events, the rest time between rounds is one (1) minute.

RULE 9. THE DECISIONS

9.1. Win on Points

- 9.1.1. At the end of a contest, the winner shall be determined on the basis of the total number of correct scoring blows scored during the bout. The boxer having scored the most correct blows shall be declared the winner. If both boxers are injured, and cannot continue the contest. In cases, the boxer having scored more points at the time when the bout is stopped shall be declared such as the winner.

9.2. Win by Retirement

- 9.2.1. If a Boxer retires voluntarily owing to injury or throwing a towel in the ring by a second, or if the Boxer fails to resume boxing immediately after the rest between rounds, the opponent shall be declared the winner.

9.3. Win by Referee Stopping Contest (RSC)

- 9.3.1. Outclassed - 'RSC' is a term used to stop a bout when a Boxer is outclassed or is unfit to continue. If a Boxer, in the opinion of the Referee is being outclassed or is receiving excessive punishment, the bout shall be stopped and the opponent declared the winner.

9.3.2. RSC Injury

- 9.3.2.1. If a Boxer, in the opinion of the doctor / Referee, is unfit to continue because of injury sustained from correct blows or other action or is incapacitated for any other physical reason, the bout shall be stopped and the opponent declared the winner by RSCI. In case both Boxers are injured at the same time, the Boxer with the higher score at time of decision will be the winner.
- 9.3.2.2. The right to make this decision rests with the Referee, who may consult with the Medical Jury or the Medical Jury has the right to direct to the Referee to stop the bout by using any form of communication methods.
- 9.3.2.3. When a Referee calls a Doctor to the ring to examine a Boxer, only these two officials should be present. No other person should be allowed into the ring, or on the apron.

9.4. Win by Disqualification

- 9.4.1. If a boxer is disqualified, this boxer's opponent shall be declared the winner. If both boxers are disqualified, the decision shall be announced accordingly.
- 9.4.2. A disqualified Boxer for any unethical behavior or disciplinary matters shall not be entitled to any prize, medal, trophy, honorable award, or grading, relating to any stage of the competition in which this Boxer has been disqualified and the misconduct should be reported to the disciplinary commission.

9.5. Win by Knock-Out

9.5.1. If a boxer is “down” and fails to resume boxing after this boxer is counted out to ten, the opponent shall be declared the winner by a knock-out.

9.6. Win by RSCH

9.6.1. If a Boxer is unfit to continue and fails to resume boxing after this Boxer having received hard blows to the head, the opponent shall be declared the winner by RSCH.

9.7. No Contest

9.7.1. A bout may be terminated by the Referee inside the scheduled distance owing to a material happening outside the responsibility of the Boxers, or the control of the Referee, such as the ring becoming damaged, the failure of the lighting supply, exceptional weather conditions, etc. In such circumstances, the bout shall be declared “no contest” and in the case of Championships, the Jury shall decide the necessary further action.

9.8. Win by Walk-Over

9.8.1. When a Boxer is present in the ring fully attired for boxing and this Boxer’s opponent fails to appear after having been called out by the public address system, the bell has sounded and a maximum period of one minute has elapsed, the Referee shall declare the first Boxer to be the winner by “walk-over”. The Referee shall first inform the Competition Jury and then shall summon the Boxer to the center of the ring and after the decision is announced, raise this Boxer’s hand as the winner.

9.9. Decision in Case of Draw

9.9.1. At the end of a contest, if the Boxers are equal in points, the decision shall be made by considering the accepted scores after deleting the highest and lowest scores of both Boxers. If the scores remain equal the decision will be made by the majority of the five (5) Judges by pressing the scoring pad once based on the following performances of the Boxers:

9.9.1.1. who has done most of the leading off or who has shown the better style; or if equal in that respect;

9.9.1.2. who has shown the better defense (blocking, parrying, ducking, side-stepping, etc.) by which the opponent’s attacks have been made to miss.

9.9.2. The final winner in each weight category shall be nominated in all AIBA Approved Events.

9.9.3. Only in Dual Matches, a draw decision may be awarded. Likewise, an injury in the first round may result in a draw in Dual Matches.

9.10. Incidents in the Ring Outside the Control of the Referee

9.10.1. If something happens that does not allow the bout to continue within one minute after the bell has rung for the beginning of the first, second, or third round (in case of 4 round bouts), e.g. power failure, the bout shall be stopped and the Boxers will box again in the last bout of the same session.

9.10.2. If the incident occurs in the last round of a bout, the contest shall be terminated and the Judges are asked to give a decision as to the winner of the bout.

9.10.3. If the bout cannot be resumed to box at the end of the same session, it will be moved to the beginning of the next session before the original schedule. If the next session is on the following day, the Boxers shall be weighed and medically examined again for the bout.

9.10.4. If bouts must be stopped and can be resumed the score will be recorded and taken over to the time to resume the bout.

9.11. Protests

- 9.11.1. A protest shall be submitted by the team leader or by the person having the highest position in the team delegation no later than 30 minutes after the completion of the bout. Any protest shall be against the decision(s) of Referee and/or Judges of the bout.
- 9.11.2. The protest shall be made in writing and handed to the Chairperson of Competition Jury with specifying definitive and clear reasons of the protest.
- 9.11.3. The protest fee is US\$ 500. An administrative fee of US\$ 100 will be deducted from this amount and the remaining amount will be refunded if the protest is upheld. If the protest is rejected, the entire fee will not be returned to the protester.
- 9.11.4. The Chairperson of the Competition Jury has a right to refuse the protest(s). In case the protest is accepted by the Chairperson of the Competition Jury, all members of the Competition Jury will evaluate the protested bout result, make a decision and report the decision to the Technical Delegate.
- 9.11.5. A video recording of the protested bout will be used to analyze the bout in all AIBA Approved Events.
- 9.11.6. A protest on the finals of a tournament should be notified within 5 minutes of completion of the bout.
- 9.11.7. In the case of a protest on the finals of a tournament, the award ceremony will be postponed till the result of the evaluation is announced.
- 9.11.8. The evaluation shall be conducted only by members of the Competition Jury involved in the bout and immediately after the session is completed. The final decision of the evaluation will be reported to the Technical Delegate and the Technical Delegate will immediately inform both team leaders verbally and thereafter in writing but no later than the weigh-in and medical examination of the next day.

RULE 10. AIBA SCORING SYSTEM

- 10.1. The AIBA Scoring System shall be used in all AIBA Approved Events.
- 10.2. In case the AIBA Scoring System is being used, no Judges' score sheets shall be kept. All information required for making up the decision is recorded by the computer and, at the end of the contest, printed out automatically.
- 10.3. If the AIBA Scoring System becomes defective, the procedure shall be as follows:

The Chairperson shall stop the bout for one (1) minute. If, during that period the system cannot be repaired, the score at the time of the breakdown will be saved and the five (5) Judges shall use hand held scoring devices and record the bout for the rest of its duration on scoring pads. At the end of the contest the Chairperson of the Jury shall collect the scoring papers from the five (5) Judges, add on the scores from the AIBA Scoring System up to the breakdown and after examination by the Jury the winner should be announced accordingly. If the AIBA Scoring System cannot be repaired then the Jury can decide to continue the session / tournament allowing the Judges to score the bouts with hand held scoring devices and bout scoring pads.
- 10.4. In all AIBA Approved Events and the Olympic Games, the AIBA Scoring System shall be operated by persons selected by AIBA and the use of an electronic scoring machine shall be compulsory.
- 10.5. In all AIBA Approved Event, the review camera is an integral part of the AIBA Scoring System, which is mandatory for all AIBA major events (World Championships, World & President Cups, Olympic Games and Olympic Qualifying Tournaments).

10.6. If AIBA Scoring System fails during the competition, Judge shall use a hand held scoring calculator or clicker device. At the end of the bout, each Jury member or Judge will write his score and sign the appropriate form.

10.7. Display of Scores:

The spectators and corners will be able to see the scores on a screen; however, the Referee, five Judges and medical juries shall not be able to see the scores during the bout.

10.7.1. In all AIBA Approved Events and the Olympic Games, the use of a public display system is compulsory.

RULE 11. SCORING POINTS

11.1. Valid Scoring Points

11.1.1. During each round, a Judge shall assess the respective scores of each Boxer according to the number of scoring blows obtained by each. Each blow to have scoring value must, without being blocked or guarded, land directly with the knuckle part of the closed glove of either hand on any part of the front or sides of the head or body above the belt. Swings landing as above described are scoring blows.

11.1.2. The awarding of points shall follow the principles: one point for every correct blow.

11.1.3. Scoring points are when at least three (3) of the five (5) Judges simultaneously record a punch that in their opinion has been delivered correctly on the 'target area'.

11.2. Non-Valid Scoring Point

11.2.1. No extra points shall be awarded for a knock-down.

RULE 12. FOULS

12.1. Type of Fouls

12.1.1. Hitting below the belt, holding, tripping, kicking, and butting with foot or knee.

12.1.2. Hits or blows with head, shoulder, forearm, elbow, throttling of the opponent, and pressing with arm or elbow in opponent's face, pressing the head of the opponent back over the ropes.

12.1.3. Hitting with open glove, the inside of the glove, wrist or side of the hand.

12.1.4. Hits landing on the back of the opponent, and especially any blow on the back of the neck or head and kidney punch.

12.1.5. Pivot blows.

12.1.6. Attack whilst holding the ropes or making any unfair use of the ropes.

12.1.7. Lying on, wrestling and throwing in the clinch.

12.1.8. An attack on an opponent who is down or who is in the act of rising.

12.1.9. Holding.

12.1.10. Holding and hitting or pulling and hitting.

- 12.1.11. Holding, or locking, of the opponent's arm or head, or pushing an arm underneath the arm of the opponent.
 - 12.1.12. Ducking below the belt of the opponent in a manner dangerous to the opponent.
 - 12.1.13. Completely passive defense by means of double cover and intentionally falling, running, or turning the back to avoid a blow.
 - 12.1.14. Inappropriate, aggressive, or offensive utterances during the round.
 - 12.1.15. Not stepping back when ordered to break.
 - 12.1.16. Attempting to strike opponent immediately after the Referee has ordered "break" and before taking a step back.
 - 12.1.17. Assaulting or behaving in an aggressive manner towards a Referee at any time.
 - 12.1.18. Spitting out gumshield (teeth protector).
 - 12.1.19. Keeping the advanced hand straight in order to obstruct the opponent's vision.
- 12.2. Cautions, Warnings, Disqualifications
- 12.2.1. The competitor who does not obey the instructions of the Referee, acts against the rules of boxing, boxes in any unsportsmanlike manner, or commits fouls, can, at the discretion of the Referee, be cautioned, warned or disqualified. If a Referee intends to warn a Boxer, the Referee shall stop the contest, and will demonstrate the infringement. The Referee will then point to the Boxer and to each of the five Judges. A Referee having once administered a warning for a particular foul, i.e. holding, cannot issue a caution for the same type of offence. A third caution for the same type of foul will mandatorily require a warning to be issued. Only three warnings may be given to the same Boxer in one contest. The third warning brings automatic disqualification.
- 12.3. When a boxer receives a Referee's warning which the majority number of Judges concur was warranted, then the warned boxer's opponent will have two (2) points added to the score by the judges pressing the appropriate button on the pad of AIBA Scoring System.
- 12.4. If the Referee has any reason to believe that a foul has been committed which the Referee has not seen, the Referee may consult the Judges.
- 12.5. Boxers shall shake hands before the beginning and after a bout. Any further shaking of hands during the bout is prohibited.
- 12.6. If a boxer's gumshield falls down for the first time, a caution will be given by the Referee. Thereafter every time the gumshield falls down a warning will be issued.
- 12.7. If the Boxer intentionally spits out his gumshield, an immediate warning shall be issued

RULE 13. BOXER DOWN

13.1. Definition of "Down"

- 13.1.1. If the Boxer touches the floor with any part of the body other than the Boxer's feet as the result of a blow or series of blows.
- 13.1.2. If the Boxer hangs helplessly on the ropes as the result of a blow or series of blows.
- 13.1.3. If the Boxer is outside or partly outside the ropes as the result of a blow or series of blows.

13.1.4. If following a hard punch the Boxer has not fallen and is not lying on the ropes, but is in a semi-conscious state and cannot, in the opinion of the Referee, continue the bout.

13.2. Counts During “Down”

13.2.1. In the case of a knock-down, the Referee shall immediately begin to count the seconds. When a Boxer is “down”, the Referee shall count from one to eight if the Boxer is ready and count from one to ten if the Boxer is continuously down with intervals of a second between the numbers, and shall indicate each second with the hand in such a manner that the Boxer who has been knocked down may be aware of the count.

Before the number “one” is counted, an interval of one second must have elapsed from the time when the Boxer is knocked down, and the time of announcing “one”.

If the opponent should not go to the neutral corner on the command of the Referee, the Referee shall stop counting until the opponent has done so. The counting shall then be continued from where it had been interrupted.

13.3. Opponent’s Responsibilities

13.3.1. If a Boxer is “down”, the Boxer’s opponent must at once go to the neutral corner as designated by the Referee.

13.4. Mandatory Eight Count

13.4.1. When a Boxer is “down” as the result of a blow, the bout shall not be continued until the Referee has reached the count of eight, even if the Boxer is ready to continue before then.

13.5. The Knock-Out

13.5.1. After the Referee has said “ten” and the word “out”, the bout ends and shall be decided as a “knock-out”.

13.6. Boxer “Down” at the End of Round

13.6.1. In the event of a Boxer being “down” at the end of any round at an AIBA Approved Event, the Referee shall continue to count. Should the Referee count up to ten, such Boxer shall be deemed to have lost the bout by a “knock-out”.

13.7. Second Time Boxer “Down” without a Fresh Blow

13.7.1. If a Boxer is “down” as the result of a blow and the bout is continued after the count of eight has been reached, but the Boxer falls again without having received a fresh blow, the Referee shall continue the counting from the count of eight at which the Referee stopped.

13.8. Both Boxers “Down”

13.8.1. If both Boxers go “down” at the same time, counting will be continued as long as one of them is still “down”. If both Boxers remain “down” until ten, the bout will be stopped and both Boxers will lose by “knock-out”.

13.8.2. If this occurs in the Semi-Finals or Finals, the Boxer with the higher score at the time of the “down” will be the winner.

13.9. Compulsory Count Limits

13.9.1. In the Elite Level, when a Boxer has three (3) compulsory counts in the same round or four (4) times for the whole bout, the Referee shall stop the contest (RSC. or RSCH).

13.9.2. In all other levels, a bout shall be stopped after two (2) compulsory counts in the same round or three (3) times for the whole bout.

13.9.3. A “down” or count caused by any foul shall not be included in the compulsory count limit.

RULE 14. AIBA COMPETITION APPROVAL

14.1. Conditions of AIBA Approval can be found in the AIBA Approved Events guidelines (Appendix C).

RULE 15. COMPETITION VENUE

15.1. Field of Play

15.1.1. The AIBA official formation of Field of Play in case of one (1) or two (2) rings can be found in the Appendix I

15.2. Required Venue Facilities

In addition to setting up the ring(s), the organizer should prepare the following venue facilities and rooms:

15.2.1. Waiting Lounge for Referees & Judges.

15.2.2. Boxers' Locker Rooms.

15.2.3. Anti-Doping Rooms.

15.2.4. Medical-Check Room (Doctor's Room).

15.2.5. Boxers' Warm-Up Room

15.2.6. Storage for Boxing Equipment.

15.2.7. Offices for AIBA, Local Organizing Committee, Technical Delegate.

15.2.8. Media/Press Office Room, Interview/Press Conference Room, Mixed Zone in accordance with the AIBA Press Guidelines.

15.2.9. Meeting Room for ITOs and Referees & Judges.

15.2.10. VIP Lounge.

15.3. Additional Venue Requirements

15.3.1. The organizers of mixed events where both men and women compete shall arrange for separate rooms where the medicals and weigh-ins may be carried out separately for men and women.

15.3.2. Medicals of women Boxers shall be carried out according to the special sports-medical guidelines to be included in the AIBA Medical Handbook.

RULE 16. AIBA ANTI-DOPING REGULATIONS

16.1. All issues related to Anti-Doping are to be found in the AIBA Anti-Doping Rules.

RULES FOR COMPETITION OFFICIALS

RULE 1. TECHNICAL DELEGATE (TD)

1.1. Qualifications

- 1.1.1. The Technical Delegate must exhibit superior leadership and management skills by having only the AIBA Technical Delegate Certificate.
- 1.1.2. Active Coach, Referee, Judge and Team Manager cannot be appointed as Technical Delegate.

1.2. Nomination & Appointment

- 1.2.1. For all AIBA Approved Events, AIBA Technical & Rules Commission nominates the candidates and the AIBA President approves, appoints and dismisses the Technical Delegate, who must be from a different country than the one where the event takes place.
- 1.2.2. For all Continental Championships, the Continental Competition Commission nominates the candidates and the Continental Confederation President approves, appoints and dismisses the Technical Delegate, who must be from a different country than the one where the event takes place.

1.3. Duties of Technical Delegate

- 1.3.1. The detailed duties are listed in Appendix A.

RULE 2. DEPUTY TECHNICAL DELEGATE

2.1. Appointment

- 2.1.1. For all AIBA events where the number of entered Boxers exceeds 500, after the final entry deadline is closed, and for the Olympic Games, AIBA may appoint a Deputy Technical Delegate.

2.2. Qualifications

- 2.2.1. The Deputy Technical Delegate must exhibit superior leadership and management skills by having only the AIBA Technical Delegate Certificate.
- 2.2.2. Active Coach, Referee, Judge and Team Manager cannot be appointed as Deputy Technical Delegate
- 2.2.3. The Deputy Technical Delegate may be from the same country than the one where the event takes place.

2.3. Duties of the Deputy Technical Delegate:

- 2.3.1. The Deputy Technical Delegate shall conduct all duties based on the instructions and guidance of the Technical Delegate.

RULE 3. COMPETITION MANAGER (CM)

- 3.1. The Competition Manager must be nominated by the Host Federation and approved by the Confederation or AIBA depending if it is a Confederation Approved Event or AIBA Approved Event.
- 3.2. The Competition Manager is responsible for following instructions and guidance of the Technical Delegate to perform the duties which are attached in Appendix A.
- 3.3. The Competition Manager shall have an excellent level of spoken English.

RULE 4. INTERNATIONAL TECHNICAL OFFICIAL (ITO)

4.1. Definition

All officials working within the Field of Play (FOP) excluding the Technical Delegate(s), the Referees & Judges and the Organizing Committee staff are called ITOs. ITOs consist of the following members:

- 4.1.1. Jury Members
- 4.1.2. Draw Commission Members
- 4.1.3. Medical Jury Members
- 4.1.4. Boxing Equipment Manager
- 4.1.5. R&J Coordinator
- 4.1.6. Other assigned positions by the Technical Delegate to work inside the FOP.

4.2. Nomination & Appointment

- 4.2.1. AIBA Executive Committee members, Chairpersons of AIBA Commissions, Technical & Rules Commission members, Refereeing & Judging Commission members and Medical Commission members are the main candidates for an ITO appointment. An active Coach, Referee, Judge and Team Manager cannot be appointed as ITO.
- 4.2.2. For all AIBA Approved Events, the Technical Delegate nominates the candidates and the AIBA President approves, appoints and dismisses the ITOs.
- 4.2.3. For all Continental Championships, the Technical Delegate nominates the candidates and the Continental Confederation President approves, appoints and dismisses the ITOs.
- 4.2.4. ITOs shall not be more than two members from the same nationality in the same event as long as these ITOs from the same nationality are not assigned in the same bout.
- 4.2.5. The Host National Federation shall not send any ITO for its hosting event

RULE 5. COMPETITION JURY

5.1. Appointment

- 5.1.1. For the Olympic Games and World Championships, the Jury shall be composed of AIBA Executive Committee members in the International List of Referees & Judges, together with the members of both the Technical & Rules and Refereeing & Judging Commissions.
- 5.1.2. On the occasion of Confederation Championships, the Competition Jury shall be composed of members of the Confederation Executive Committee, Refereeing & Judging and Competition Commissions who have been certified AIBA Referees & Judges

5.2. Composition of Members in Competition

- 5.2.1. At each boxing session (other than the finals) the Jury shall consist of 3 persons according to 4.1.1 of which one is the Chairperson.

5.3. Position and Rotation of Members in Competition

- 5.3.1. No one other than members of the Jury shall sit at the Jury table during sessions. The rotation of the Jury members for each session shall be arranged prior to the commencement of the competition by the Technical Delegate. Members wishing to change places on the rotation must first obtain the consent of the Technical Delegate

5.4. Procedure of Making Decisions

- 5.4.1. The Chairperson shall announce all decisions on behalf of all Jury members.

5.5. The Duties

- 5.5.1. The Chairperson shall make the announcer aware of the name of the Boxer shown as the winner on the monitor of the computer after the bout is over.
- 5.5.2. The Jury members should watch the scores and performances of the Referees & Judges and immediately suspend any wrong-doing Referee & Judge for the rest of the day's competition. Then, after the competition is completed, the Technical Delegate and 3 Jury members shall discuss any further recommendations to the Disciplinary Commission regarding sanctioning the Referee & Judge.
- 5.5.3. If an official appointed for a contest is absent, the Chairperson may appoint from the roll of approved officials a suitable member to replace the absent member, reporting this change to the Executive Committee or Continental Confederation concerned as soon as it may be possible.
- 5.5.4. If circumstances should arise which would militate against the holding of a contest under proper conditions and if a Referee should take no efficient action concerning the situation, the Chairperson may order boxing to cease until it may be satisfactorily resumed.
- 5.5.5. The Chairperson may also take any immediate action as may be considered necessary to deal with circumstances which would militate against the proper conduct of boxing at any session.
- 5.5.6. Should the Boxer be guilty of a serious and deliberate offence that is contrary to the spirit of sportsmanship, the Chairperson, the Referee, the Competition Jury, an ITO and the EC Bureau have the right to recommend the case to the Disciplinary Commission for possible sanction.

- 5.5.7. The Jury members may not act as such in bouts involving boxers from their own countries.
- 5.6. Overruling the Referee
- 5.6.1. A decision of a Referee may be overruled by the Chairperson when the Referee has given a decision which is clearly against the AIBA Statutes and Bylaws. When considering such an incident, the Jury members may use a video tape recording of the incident.
- 5.7. Conflict of Interest
- 5.7.1. Jury members officiating at the Olympic Games, World Championships, World Cup, AIBA Challenge Matches and Continental Championships shall not officiate as Referees & Judges at those Games or Championships.
- 5.8. Neutrality
- 5.8.1. Jury members at international boxing tournaments shall come from different countries.
- 5.9. Results must be displayed in a "Running Score". The AIBA Scoring System operator shall supply an immediate evaluation of the Judges' results in each bout to the Jury members.
- 5.10. The Competition Jury Chairperson shall conduct the pre-session Referee & Judge meeting.

RULE 6. RULES FOR BOTH REFEREES & JUDGES

6.1. Designation and Neutrality

To ensure neutrality, the names of the Referee and of the five Judges for each contest shall be selected by a Computerized Software Program and/or a Draw Commission.

- 6.1.1. Each of such officials shall be an approved Referee & Judge.
- 6.1.2. Each of such officials shall be of a different country and Federation from each other and from each of the Boxers taking part in the contest.
- 6.1.3. Each of such officials shall not be a national of or resident in any country which is a dominion, colony or dependency of the country of any of the Boxers taking part in the contest.
- 6.1.4. In the event of a change of a country of any official, such official shall not officiate in any contest in which a Boxer of the official's original country is taking part, or a Referee & Judge of that country is officiating.
- 6.1.5. In case(s) if the Draw Commission cannot apply the above directives, the difficulty shall be resolved by ensuring as far as it may be possible the neutrality and impartiality of the officials appointed, and shall report the matter as soon as convenient to the Executive Committee.
- 6.1.6. In the event it is impossible for the Draw Commission in any case to comply with the above directives, the name or names of an official or officials may be drawn by lot by the Chairperson of the Draw Commission or someone acting on this Chairperson's behalf, for the contest in question.
- 6.1.7. One Judge may be selected from the continent of each Boxer and three (3) Judges selected from other continents. In any case there shall not be more than two officials in one and the same contest coming from the same continent.

- 6.1.8. In relation to the three other Judges, it is not possible to select two Judges from the same continent. The selection of Referees & Judges by draw will ensure neutrality by complying with the following points.
 - 6.1.8.1. They will be from different continents and three will be from three (3) different continents and will be from different countries than the boxers.
 - 6.1.8.2. It is forbidden to officiate if a boxer is from a country that was previously the main nation of the Referee & Judge.
- 6.2. Conflict of Interest
 - 6.2.1. Referees & Judges in any contest or series of contests shall not at any time during the same contest or series of contests act as team manager, trainer or second to any Boxer or team of Boxers taking part in such contest or series of contests or so act in a contest in which a competitor of their nationality is taking part.
- 6.3. Disciplinary Action
 - 6.3.1. A decision on suspension related to Judges or Referees shall be made by the Disciplinary Commission.
- 6.4. Code of conduct
 - 6.4.1. All Referees & Judges should respect and sign the AIBA Code of Conduct (Appendix B).

RULE 7. REFEREES

- 7.1. Designation and Participation
 - 7.1.1. In the Olympic Games and all AIBA Approved Events, each contest shall be controlled by an AIBA approved Referee who shall officiate on the ring and shall not score the bout.
- 7.2. Duties
 - 7.2.1. The care of the Boxer should be the primary concern of the Referee.
 - 7.2.2. To see that rules and fair play are strictly observed.
 - 7.2.3. To maintain control of the contest at all its stages.
 - 7.2.4. To prevent a weak Boxer from receiving undue and unnecessary punishment.
 - 7.2.5. To use three words of command:
 - 7.2.5.1. "Stop" when ordering the boxers to stop boxing.
 - 7.2.5.2. "Box" when ordering the boxers to continue boxing.
 - 7.2.5.3. "Break" when breaking a clinch, upon which command each boxer shall step back before continuing boxing.
 - 7.2.6. To indicate to a Boxer by suitable explanatory signs or gestures any infringement of the rules.
 - 7.2.7. In case of one or both Boxers are deaf, the Referee can use a touch by hand on the shoulder or on the arm to "stop" and to "break" the bout.
 - 7.2.8. The Referee shall not indicate the winner, by raising a Boxer's hand or otherwise, until the announcement has been made. When the winner of a bout is announced, the Referee shall raise the hand of the winning Boxer.

- 7.2.9. When the Referee has disqualified a Boxer or stopped the bout, the Referee shall first inform the Chairperson of the Jury which Boxer has been disqualified or the reason for which the bout was stopped, to enable the Chairperson of the Jury to instruct the announcer to make the decision correctly known to the public.
- 7.3. Authorities of the Referee
- 7.3.1. To terminate a contest at any stage if this Referee considers it to be one-sided.
- 7.3.2. To terminate a contest at any stage if one of the boxers has received an injury on account of which the Referee decides the boxer should not continue.
- 7.3.3. To terminate a contest at any stage if this Referee considers the contestants are not in earnest. In such cases, the Referee may disqualify one or both contestants.
- 7.3.4. To caution a boxer or to stop the boxing during a contest and administer a warning to a boxer against fouls or for any other reason in the interest of fair play, or to ensure compliance with the rules.
- 7.3.5. To disqualify a boxer who fails to comply immediately with the Referee's orders, or behaves towards the Referee in an offensive or aggressive manner at any time.
- 7.3.6. To caution, to remove and to disqualify a second who has infringed the rules.
- 7.3.7. With or without previous warning, to disqualify a contestant for committing a foul.
- 7.3.8. In the event of a knock-down, to suspend a count, if a boxer deliberately fails to retire to a neutral corner or delays to do so.
- 7.3.9. To interpret the rules insofar as they are applicable or relevant to the actual contest or to decide and take action on any circumstance of the contest which is not covered by a rule.
- 7.3.10. Medical Check - A Referee, before officiating in any international tournament conducted under these rules, shall undergo a medical examination as to physical fitness for carrying out Referee's duties in the ring. The Referee's vision shall be correctable to 20/80 or better. The wearing of spectacles by a Referee during the progress of a bout is not permitted, but contact lenses are allowed. It will be compulsory for the Referee to take part in a meeting arranged by the Medical Jury before each Championship.
- 7.4. Right to Check the Boxer
- 7.4.1. Equipment and Uniform - Once a Boxer enters the ring, a Referee shall disqualify from competition any Boxer who refuse to wear a headguard, a cup-protector (only men), and gumshield; however this situation can be immediately rectified at Referee's discretion within one minute failing which the Boxer will be disqualified. No other objects may be worn during the competition. In the event of a Boxer's glove or dress becoming undone during boxing, the Referee shall stop the contest to have it attended to.
- 7.5. Right to Check the Judges
- 7.5.1. The Referee must check the right positions of judges before the bout.

RULE 8. JUDGES

8.1. Designation and Participation

- 8.1.1. In the Olympic Games and all AIBA Approved Events, each contest shall be marked by five AIBA Judges who shall be seated separated from the public and immediately adjacent to the ring.
- 8.1.2. Two of the Judges shall be seated on the same side of the ring at a sufficient distance from one another, and each of the other three Judges shall be seated at the center of one of the other three sides of the ring.

When the number of officials available is insufficient, 3 Judges instead of 5 may be used, but this shall not apply to the Olympic Games, World Championships or Continental Championships.

8.2. Duties

- 8.2.1. Each Judge shall independently Judge the merits of the two contestants and shall decide the winner according to the rules.
- 8.2.2. Each Judge shall use the AIBA Scoring System for judging the merits of the Boxers.
- 8.2.3. Each Judge shall not speak or give any sign to a contestant or to another Judge or to anyone else during the contest.
- 8.2.4. Each Judge can, should it be necessary, at the end of a round, bring to the attention of the Referee any incident which the Referee may appear not to have noticed such as the misconduct of a second, loose ropes etc.
- 8.2.5. Judges shall remain in their seated positions until after the verdict has been announced to the public.

RULE 9. AIBA REFEREES & JUDGES MANAGEMENT

- 9.1. The entire management system for AIBA Referees and Judges is described in Appendix G.

RULE 10. COACHES

10.1. Certification

- 10.1.1. All current coaches in National Federations must obtain an AIBA official certification to be allowed to second Boxers in the different AIBA Approved Events.
- 10.1.2. The coach classification shall be divided in 3 levels and respect the following principles:
 - 10.1.2.1. 1 Star level coaches and above are allowed to be second at 1 star level events
 - 10.1.2.2. 2 Stars level coaches and above are allowed to be second at 2 star level events
 - 10.1.2.3. Only 3 Stars level coaches are allowed to be second at 3 star level events
- 10.2. Until the new Coaches Management System is in place, a grace period shall be opened until the end of December 2012 to allow a lower Star level coach to perform as second in any higher level event in case a National Federation does not have any sufficient level certified coaches

RULE 11. SECONDS

11.1. Number of Seconds

- 11.1.1. Each competitor is entitled to two (2) seconds who shall be governed by the following rule: Only the two (2) seconds shall mount the apron of the ring and only one may enter the ring.

11.2. Duties

- 11.2.1. During the boxing, none of the seconds shall remain on the platform of the ring. Before a round begins, they shall remove seats, towels, buckets, etc., from the platform of the ring.
- 11.2.2. The seconds, while officiating in the corner, shall be in possession of a towel for the Boxer. A second may indicate retirement for the Boxer by throwing the towel into the ring, when the second considers the Boxer to be unfit / unable to continue boxing, except when the Referee is in the course of counting.
- 11.2.3. The seconds are the coaches and trainers who are qualified in their National Federations and must respect and follow the AIBA rules and each Boxer is also responsible in a same way for seconds.

11.3. Prohibited Activities

- 11.3.1. Any second encouraging or inciting spectators by words or signs during the progress of a round shall not be permitted to continue to act as a second at the tournament where the offence is committed.
- 11.3.2. Once a second is removed from the corner by the Referee, this second shall leave the Field of Play for the remainder of the session. If, during the tournament, this second is removed for a second time, this second shall be completely suspended from that tournament.
- 11.3.3. Use of any communication devices shall not be permitted in the Field of Play such as but not limited to mobile phones, walkie-talkies, smart phones, headsets, shortwave radios, etc.

RULE 12. MEDICAL JURY

12.1. Qualification

- 12.1.1. A qualified Doctor of medicine, licensed in good standing in own country and certified by AIBA, shall be appointed by the Chairman of the AIBA Medical Commission. If possible, a licensed Ringside Physician certified by AIBA shall be appointed by the Chairman of the AIBA Medical Commission.
- 12.1.2. In all AIBA Approved Events, Olympic Games, Olympic Qualifying Events, only AIBA Medical Commission members are permitted to serve as Medical Jury members. For all Confederation approved events, only Confederation Medical Commission members are permitted to serve as the Medical Jury members.
- 12.1.3. In Emergency conditions, the Technical Delegate may appoint local or team doctors in case other medical Jury members are not available.

12.2. Attendance in Competition

12.2.1. That Doctor of medicine should be in attendance throughout the competition and should not leave the place where it is held before the end of the last bout and until this Doctor has seen the two Boxers who participated in such bout. The Medical Jury may wear surgical gloves during the bout.

12.3. Number of Medical Jury

12.3.1. In the case of one ring, in all AIBA Approved Events including the Olympic Games and World Championships, a minimum of two (2) and maximum of three (3) AIBA Medical Jury members are appointed. However, in any case, there shall not be more than two (2) Medical Jury members at one ringside.

12.3.2. In the case of two rings, in all AIBA Approved Events including the Olympic Games and World Championships, a maximum of two (2) AIBA Medical Jury members for each ring is required.

12.4. Requirement of Anti-Doping Jury

12.4.1. For any of AIBA Approved Events, one (1) anti-doping specialist should be present to control the anti-doping process under the supervision of the AIBA Medical Jury members.

12.5. Main Duties of Medical Jury

12.5.1. General Duties

12.5.1.1. The AIBA Medical Jury checks are designated for Medical Examinations to ensure that:

- The competitors have enough space.
- There is a direct access to the weighing-in room.
- There exists some heating (if necessary), sufficient light and good ventilation.
- There are a sufficient number of chairs and desks

12.5.1.2. An AIBA Medical Commission member shall be present at the initial medical examination and all subsequent pre-bout examinations of Boxers at all international competitions.

12.5.1.3. AIBA Medical Jury members shall assist medical officers from individual countries.

12.5.1.4. AIBA Medical Jury members may express opinions on injuries that Boxers have sustained. This opinion will be considered as final.

12.5.1.5. The AIBA Medical Jury provides a physician to oversee doping procedures and inspects the designated doping areas to determine their adequacy in location, equipment, provisions, and forms.

12.5.1.6. The AIBA Medical Jury provides medical examinations for AIBA Referees & Judges.

12.5.1.7. The AIBA Medical Jury reviews the emergency plans of the tournament organizers

- Checks for the presence of oxygen and stretcher, other resuscitation equipment, evacuation equipment, route of evacuation.
- Checks that an ambulance is present for competition and hospital designated to care for stricken athletes.

12.5.1.8. The AIBA Medical Jury checks for adequate food and hydration provisions for the athletes and recommends to the Technical Delegate for approval.

12.5.2. Competition Duties

12.5.2.1. At least one member of the AIBA Medical Jury must be at ringside for the entire duration of a bout.

12.5.2.2. AIBA Medical Jury members shall direct the Referee in evaluating injuries.

12.5.2.3. AIBA Medical Jury members shall inform the Chairperson of the Competition Jury to stop the bout in the case of any athlete appears unable to continue.

12.5.3. Procedure after Knock-Outs and RSCH

12.5.3.1. Unconscious Boxer - If a Boxer is rendered unconscious, then only the Referee and the Doctor summoned should remain in the ring, unless the Doctor needs extra help. In the case a Boxer is unconscious for more than one (1) minute, this Boxer should be transported to the nearest hospital (if possible to the neurosurgery department) for further evaluation. Any Boxer with a concussion may be referred to the hospital by the Doctor.

12.5.3.2. Medical Attention - In the case of a knock-out without unconsciousness or in the case of RSCH, the Boxer shall be examined by a Doctor immediately afterwards in the locker room to determine the need and nature of further medical observation and/or hospitalization.

12.5.3.3. AIBA Medical Jury members will provide first aid to the unconscious Boxer until care is transferred to the local medical support team for definitive management.

12.5.3.4. AIBA Medical Jury members may recommend treatment for injured Boxers.

12.5.3.5. AIBA Medical Jury members will suspend and restrict injured Boxers as they feel appropriate.

RULE 13. TIMEKEEPER

13.1. Duties

13.1.1. The main duty of the Timekeeper is to regulate the number and duration of the rounds and the intervals between rounds. The intervals between rounds shall be of a full minute duration.

13.1.2. Five seconds before the commencement of each round, the Timekeeper shall clear the ring by ordering "clear the ring" or "seconds out".

13.1.3. The Timekeeper shall commence and end each round by striking the gong or bell.

13.1.4. The Timekeeper shall announce the number of each round immediately prior to commencing it.

13.1.5. The Timekeeper shall stop/resume the clock as instructed by the Referee.

- 13.1.6. The Timekeeper shall regulate all periods of time and counts by a watch or clock.
- 13.1.7. At a “knock-down”, the Timekeeper shall give the sound signal to the Referee indicating the elapsing seconds while the latter is counting.
- 13.1.8. If, at the end of a round, a Boxer is “down” and the Referee is in the course of counting, the gong indicating the end of the round will not be sounded. The gong will be sounded only when the Referee gives the command “box” indicating the continuation of the match. When the Referee is in the course of counting, the time of the round cannot finish, because of the command “stop” given by the Referee.

13.2. Position

- 13.2.1. The Timekeeper shall be seated directly at the side of the ring.

RULE 14. OFFICIAL ANNOUNCER

14.1. Qualification

- 14.1.1. For all AIBA Approved Events, the Official announcer should have the following qualifications:
 - 14.1.1.1. Fluent in multi-languages (English is mandatory).
 - 14.1.1.2. An excellent understanding of the AIBA Technical & Competition Rules.
 - 14.1.1.3. Possess a minimum of three (3) years experience in the field of competition announcement in sports events.

14.2. Appointment

- 14.2.1. The Event Organizing Committee is responsible to hire a professional announcer for the entire competition.

RULES FOR COMPETITION EQUIPMENT

RULE 1. THE RING AND ACCESSORIES

- 1.1. All specifications and guidelines on ring and accessories are described in Appendix H.
- 1.2. Approved Label
 - 1.2.1. For all AIBA Approved Events, the Organizing Committee should use the rings manufactured by one of the AIBA Official Licensees.
 - 1.2.2. All existing rings can be used until the end of 2010. However, from 2011, for all AIBA Approved Events, a new ring with AIBA approved labels must be used.

RULE 2. BOXING GLOVES

- 2.1. All AIBA Approved Events must use gloves manufactured by one of the AIBA Official Boxing Equipment Licensees.
- 2.2. Competitors shall wear red or blue gloves, as per the respective Boxer's corner.
- 2.3. At all AIBA Approved Events, the gloves have to be provided by the Organizing Committee and have to be approved by the Technical Delegate. Boxers are not allowed to wear their own gloves.
- 2.4. Boxers shall put on their boxing gloves before entering the ring.
- 2.5. The gloves shall be taken off immediately after the bout is over and before the decision is announced.
- 2.6. The padding of the gloves shall not be displaced or broken.
- 2.7. Only clean and serviceable gloves shall be used.
- 2.8. Specifications
 - 2.8.1. Detailed specification of Boxing Gloves can be found in the Equipment guideline Appendix J.

RULE 3. HEADGUARDS

- 3.1. At all AIBA Approved Events, Boxers must use headguards manufactured by one of the AIBA Official Boxing Equipment Licensees.
- 3.2. The use of a headguard is mandatory.
- 3.3. Competitors shall wear red or blue headguards, as per the respective Boxer's corner.
- 3.4. At all AIBA Approved Events, the headguards have to be provided by the Organizing Committee and have to be approved by the Technical Delegate. Boxers are not allowed to wear their own headguard.
- 3.5. Boxers shall put their headguard on only after entering the ring.
- 3.6. The headguard shall be taken off immediately after the bout is over and before the decision is announced.

3.7. Specifications

3.7.1. Detailed specification of headguards can be found in the Equipment guideline Appendix J.

RULE 4. BANDAGES

4.1. Use of Bandages

4.1.1. All AIBA Approved Events must use bandages from one of the AIBA Official Boxing Equipment Licensees.

4.1.2. At all 3 Star Events, the Organizing Committee shall provide at each bout, new bandages to the Boxer upon the Boxer's arrival at the competition venue for the boxing session in which the Boxer is scheduled to compete.

4.1.3. Bandages shall be applied in the dressing room in the presence of a Host Federation Official. The bandages on each Boxer shall be checked and marked by an Official Equipment Manager at the equipment check table.

4.2. Specifications

4.2.1. A bandage must not be longer than 4.5m. (14.76 feet), and not shorter than 2.5m (8.2 feet). The bandage should be 5.7cm (2 ¼ inches) wide. It should be made of a stretched material and have an AIBA approved closing system.

RULE 5. GUMSHIELD

5.1. A gumshield must be worn. The gumshield should be form-fitted. The gumshield must be made available by the Organizing Committee for any participant who does not have one, against payment by the Boxer concerned or the Boxer's National Federation. No red or partially red colored gumshield may be worn.

5.2. It shall be forbidden for a Boxer to intentionally remove the gumshield during the contest and if the Boxer does so, this Boxer shall be warned or disqualified. If a Boxer has the gumshield knocked out, the Referee shall take the Boxer to the Boxer's corner, have the gumshield washed and returned to its proper position. While this is being done, the second is not allowed to talk to the Boxer.

RULE 6. PROTECTORS

6.1. For Men Competition a cup protector shall be worn by men Boxers during all bouts and a jock-strap may be worn additionally. The cup protector should not cover any part of the target area.

6.2. For Women Competition breast protector and Pubic protector may be worn by women Boxers.

RULE 7. COMPETITION UNIFORM

7.1. Boxer's Uniform

7.1.1. Competitors shall box in light boots or shoes (without spikes or heels), socks, short (not to exceed knee length), and a vest covering the chest and back as shown on the following drawing.

7.1.2. For all AIBA Approved Events, the Boxers may wear red or blue vest and short as per the Boxers' respective corner allocation, which shall be their own responsibility. The belt line must be clearly indicated by using a 10cm wide elastic waistband (the belt line is an imaginary line from the navel to the top of the hips).

7.2. Specifications

7.2.1. Detailed Boxer's Uniform guideline can be found on Appendix F.

7.3. Attire of the Officials (Referees & Judges)

7.3.1. Referees & Judges shall be dressed in white trousers, white shirt and light shoes or boots without raised heels

7.3.2. In AIBA Controlled Events or Events where Referees & Judges are provided with uniforms by AIBA, Referees & Judges must wear the provided uniforms.

7.3.3. These officials may use surgical gloves when officiating.

RULE 8. AIBA SCORING SYSTEM EQUIPMENT

8.1. For all AIBA Approved Events, a complete set(s) of AIBA Scoring System approved by AIBA, and an AIBA Scoring System operator are mandatory.

8.2. Handheld Calculators, handheld clickers

8.2.1. The Judges will also require five (5) handheld scoring machines (scoring calculators – clickers) in the event of a breakdown of the AIBA Scoring System.

APPENDIX A

DUTIES OF TECHNICAL DELEGATE & COMPETITION MANAGER

1. DUTIES OF TECHNICAL DELEGATE

- 1.1. To conduct inspection visit (or visits) prior to the event in order to check the preparations of the Local Organizing Committee in regard to all technical areas including venue, competition related facilities, competition schedules, location of Team Delegation hotel, etc., along with AIBA or Confederation HQs Office staff.
- 1.2. To evaluate the progress of preparations for the event and report to the AIBA HQs Office.
- 1.3. To arrive in good time for the event in order to monitor and assist the Organizing Committee with the final preparations. The Technical Delegate shall intervene in the work of the Organizing Committee only in the event of AIBA Technical & Competition Rules being infringed or where the Technical Delegate has been requested to offer assistance.
- 1.4. To conduct the Technical Meeting for Team Leaders, Coaches, Doctors, Referees & Judges and officials prior to the commencement of competition.
- 1.5. To supervise / monitor the arrangements for the Official Draw, the General Weigh-In, the daily medical check and daily schedule of contests.
- 1.6. To assign the duties of appointed ITOs in the competition.
- 1.7. To supervise / monitor the appointment process for the following officials / duties: Passport control and record book checks, weigh-in scales, Referees & Judges, Draw Commission, updating of record book at ringside, Jury members, appeal procedures.
- 1.8. To conduct a daily meeting among Chairpersons of Competition Jury and Draw Commission in order to evaluate the performance of the Referees & Judges and make the final decisions on all matters related to the Referees & Judges based on the outcomes of the meeting.
- 1.9. To submit the final evaluation report of the competition to the AIBA or Confederation HQs Office.

2. DUTIES OF COMPETITION MANAGER

- 2.1. To oversee the running of the competition and provide the focal point for AIBA contact in relation to competition issues.
- 2.2. To ensure that the competition is organized and conducted in accordance with AIBA Technical & Competition Rules under the guidance of the Technical Delegate(s).
- 2.3. To liaise with other functional areas to ensure the coordinated delivery of support services such as accreditation, security, transport, medical, media, venue operations, venues, host broadcaster and volunteers.
- 2.4. To liaise regularly with the Technical Delegate(s) and Host National Federation and Organizing Committee on matters relating to the preparation of the competition.
- 2.5. To report to AIBA and the Technical Delegate on a regular basis about the preparation of the event.
- 2.6. To establish a list of equipment required for the boxing competition.

- 2.7. To provide a specific sport input into venue planning and operations for all competition and training sites.
- 2.8. To recommend an appropriate organizational structure and appropriate staffing levels for the conduct of the competition.
- 2.9. To train and manage staff and volunteers on a day-to-day basis.
- 2.10. To collaborate with the Host National Federation and Organizing Committee regarding the selection and training of the National Technical Officials.
- 2.11. To organize and conduct orientation and briefing sessions for all staff, technical officials, and volunteers prior to the commencement of the competition.
- 2.12. To ensure all assets of the Organizing Committee assigned to an area are properly secured and maintained.
- 2.13. To ensure all policies and procedures of the Organizing Committee are followed, venue emergency procedures are in place and related issues (e.g. discipline, security, working conditions, etc.) are properly enforced, documented and irregularities reported.
- 2.14. To attend such meetings and undertake such liaison as may be necessary as Competition Manager, reporting and taking action as required.

APPENDIX B AIBA CODE OF CONDUCT

The International Boxing Association (AIBA) hereby requests for your agreement of the following “Code of Conduct”, which will be applied during the entire period of the [Name Event, Date Event].

- Code 1: I shall not receive any cash and shall not accept any gifts that could be considered as a bribe from anyone excluding those to be received from the AIBA HQs Office as official souvenirs.
- Code 2: I shall not be under the influence of alcohol during the entire period of the [Name Event].
- Code 3: I shall not violate any norms of social behavior in my relation with members of the local and visiting countries' citizens.
- Code 4: I shall not use or carry my mobile telephone inside of the competition venue.
- Code 5: I shall be available to attend all daily arranged Referees & Judges meetings for the entire period of the [Name Event].
- Code 6: I shall be available for fulfilling my duties for the competition as requested by the AIBA Technical Delegate.
- Code 7: I shall not collude or collaborate with any party by violating any of the AIBA Technical & Competition Rules.
- Code 8: I shall not collude or collaborate with any party by violating my judgment and duties as an AIBA Referee & Judge.
- Code 9: When performing my duties as an AIBA Referee & Judge, I shall not talk to anybody about any competition related issues within the competition venue and/or any other location for the entire period of the competition, especially to persons from my own country such as National Federation members, International Technical Officials, Executive Committee members, media and public.
- Code 10: I shall not conduct myself in any manner that is derogatory to AIBA.
- Code 11: I shall not smoke inside of the competition venue.
- Code 12: I shall respect and not violate the AIBA Disciplinary Code in any manner.

I accept the fact that any infringement of the above codes will be referred to the AIBA Disciplinary Commission / Executive Committee and could lead to immediate sanction against me. Therefore, I hereby agree to AIBA's request.

Date: _____ / _____ / _____

NAME

FUNCTION

SIGNATURE

APPENDIX C

APPROVED EVENTS GUIDELINE

1. AIBA APPROVED EVENTS

- 1.1. AIBA Approved Events are supported by AIBA through TV rights, sponsorships, Technical Delegates, R&Js depending on the defined level of the event as listed in 1.10.
- 1.2. In each year, AIBA will set the maximum number of the AIBA Approved Events will be held in any one calendar year at the EC meeting.
- 1.3. An AIBA Approved Event may not be staged on the same day as another one, unless the two events are in different countries and do not share a common border.
- 1.4. In principle, no more than one (1) AIBA Approved Event may be staged in the same city in any one year.
- 1.5. A maximum of three (3) AIBA Approved Events can be staged in any one country depending on their consistent excellence and their tradition.
- 1.6. AIBA will only consider applications for AIBA Status from those countries that have previously held an International Tournament on a regular basis and which are approved by the National Federation.
- 1.7. Applications for AIBA Status shall be submitted by National Federations by September of the year preceding the event.
- 1.8. Any National Federation applying for an upgrading of status shall submit, in its application, the results of the last tournament and details to support such upgrading.
- 1.9. Any applying Federation for any AIBA Approved Events will need to fulfill AIBA's requirements such as budget, fee, compliance with AIBA Technical & Competition Rules, Anti-Doping Code, TV coverage. The level of requirements will depend on the status of the Approved Event.
- 1.10. AIBA Approved Events are divided into three levels (1 Star - 2 Star – 3 Star Events) depending on the number of Boxers participating from different countries and the level of the Boxers (World Ranked Boxers):
 - 1.10.1. AIBA 3 stars events – AIBA International Tournaments:
 - 1.10.1.1. All AIBA CONTROLLED EVENTS as follows are controlled, managed by AIBA and the rights belong to AIBA:
 - AIBA World Boxing Championships
 - AIBA President's Cup
 - AIBA World Cup
 - All Qualifying Events for the Olympic Games and Youth Olympic Games.
 - 1.10.1.2. International and continental events with more than 20 countries' participation with over 150 boxers
 - 1.10.1.3. 5 Confederation Championships
 - 1.10.2. AIBA 2 stars events – AIBA Continental Tournaments:
 - 1.10.2.1. International and continental events between 13 – 19 countries' participation with over 100 boxers

- 1.10.3. AIBA 1 stars events – AIBA Regional Tournaments:
 - 1.10.3.1. International and continental events between 1 – 12 countries' participation
- 1.11. The Rules shall apply as follows:
 - 1.11.1. The AIBA Technical & Competition Rules shall apply to all AIBA Approved Events.
 - 1.11.2. The Anti-Doping Rules shall apply to all AIBA Approved Events, except that, where the IOC, or another international organization recognized by AIBA for such purpose, carries out doping control at a competition under its rules, such as the Olympic Games, and those rules shall govern to the extent applicable.

2. EVENT PROCEDURE APPROVAL

- 2.1. National Level Events:
 - 2.1.1. For National Level Events approval needs to respect the following approval order procedure:
 - 2.1.1.1. National Federation's approval is mandatory
 - 2.1.1.2. Confederation's approval is mandatory
 - 2.1.1.3. AIBA's approval may be requested
 - 2.1.2. All other events may be AIBA Approved Events or not, for which the Host Federation has the liberty to choose. However, in the case of non-approved events, the AIBA Technical & Competition Rules must apply.
 - 2.1.3. An approval should be obtained no later than 3 months before the competition starts.
 - 2.1.4. This procedure may be implemented for any Championships, Dual Matches, Invitations (team or individual) or all other regional events.
- 2.2. Continental Events:
 - 2.2.1. For Continental Level Events, approval needs to be given by the Confederation and/or by AIBA.
 - 2.2.2. This can be done for Confederation Championships, continental events and international multi-continental events.

APPENDIX D WORLD RANKING GUIDELINE

1. WORLD RANKING POINTS ALLOCATION

- 1.1. The World Ranking points for each Boxer are accumulated over a two year “rolling” period.
- 1.2. The World Ranking points will be awarded for each event and maintained in full for four (4) events (to place additional emphasis on recent performances).
- 1.3. The World Ranking points of the 5th event onwards will then be reduced by 25% in equal decrements for the remaining events (at most, 7 events will be included in the ranking system).
- 1.4. The Official AIBA World Ranking is issued after each event counting into the ranking system.
- 1.5. Every Boxer participating in a 3 Star Event as listed in Appendix C will be ranked within the competition and will gain points depending on final result and position.
- 1.6. The allocation of points to be earned is as follows:

Ranking Events	Ranking points to earn for reaching the following place									
	1st	2nd	3rd	4th	5th	6th	7th	8th	9th	10th
World Championships	1200	800	700	650	500	450	400	350	100	90
Olympic Games	1300	900	800	750	600	550	500	450	100	0
Continental Olympic Qualifying event	750	550	450	400	250	200	150	100	0	0
Confederation Championships	800	600	500	450	300	250	200	150	0	0
Youth World Championships	800	600	500	450	300	250	200	150	0	0

- 1.7. For the World Championships (the first Olympic Qualifying Tournament) and Olympic Qualifying Tournaments in each continent, AIBA will allow the points which are the highest one among these participations.

2. EXTRA CRITERIAS

- 2.1. Any Boxer who changes weight category will be awarded 75% of all granted points in the previous weight category.
- 2.2. Two Boxers with the same amount of points will be **FIRSTLY** ranked by the number of competitions in which they participated.
- 2.3. In case two Boxers have the same number of points gained in the same number of competitions, they will be ranked through the best result in highest ranked competition as follows:
 - 2.3.1. Olympic Games
 - 2.3.2. World Championship
 - 2.3.3. Youth World Championship
 - 2.3.4. Olympic Qualifier
 - 2.3.5. Confederation Championship

APPENDIX E

SEEDING PROCEDURE OF THE DRAW CEREMONY

1. THE SEEDING PROCEDURE OF THE DRAW CEREMONY

- 1.1. To ensure even strength throughout the draw and to avoid best World Ranked Boxers meeting in the early rounds, the draw may be seeded or arranged subject to the restrictions for each different AIBA Approved Events as follows:
 - 1.1.1. World Championships
 - 1.1.1.1. eight seeds per weight category for Elite Men World Championships
 - 1.1.2. Olympic Games
 - 1.1.2.1. A maximum of two seeds if there are less than 16 entries in the weight category;
 - 1.1.2.2. a maximum of four seeds if there are 16 to 31 entries in the weight category;
 - 1.1.2.3. a maximum of eight seeds if there are 32 to 63 entries in the weight category;
 - 1.1.3. Confederation Championships
 - 1.1.3.1. A maximum of two seeds if there are less than 16 entries in the weight category;
 - 1.1.3.2. a maximum of four seeds if there are 16 to 31 entries in the weight category;
 - 1.1.3.3. a maximum of eight seeds if there are 32 to 63 entries in the weight category;
- 1.2. For the Approved Events listed in rule 1.1., the seeding of the draw shall be controlled by AIBA. To accomplish this, all entries shall be forwarded by the organizing committee to the AIBA HQs Office.
- 1.3. The draw shall be conducted as follows:
 - 1.3.1. The number of byes should be defined and placed as follows
 - 1.3.1.1. When the number of Boxers is 4, 8, 16, 32, 64, 128, or any higher power of 2, they shall meet in pairs in the order drawn, as in Diagram 1, for eight Boxers.
 - 1.3.1.2. When the number of Boxers is not a power of 2, there shall be byes in the first round of bouts. The number of byes shall be equal to the difference between the next higher power of 2 and the number of Boxers (eg. with 17 Boxers, there are $32 - 17 = 15$ byes).
 - 1.3.1.3. The byes shall be placed as in Diagram 2.
 - 1.3.2. The seeded entries shall be selected as the best AIBA World Ranked Boxers in the event.
 - 1.3.3. Seeded entries shall be placed as detailed in the example draw in Diagram 2. Seeded entries in the top half of the draw are placed at the top and bottom of their sections (eg. eights or sixteenths), and in the bottom half of the draw at the bottom and top of their sections.

- 1.3.3.1. Depending on the number of seeds as listed in rule 1.1., the top 2 and 4 seeded entries shall be dealt with as follows and shown in Diagram 2 and Diagram 3 (eg. 1 seed, 2 seed, 3 seed, 4 seed)
- Number 1 placed at the top of the draw.
 - Number 2 placed at the bottom of the draw.
 - Number 3 placed at the top half of the bottom of the draw.
 - Number 4 placed at the bottom half of the top of the draw.
- 1.3.3.2. The other seeds shall be dealt with taking regard of the requirements of rule 1.1.
- 1.3.3.3. Numbers 5 to 8 drawn by an independent panel of observers to the remaining eights of the draw as shown in Diagram 2 and Diagram 3 (eg. 5-8 seed).
- 1.3.3.4. The remaining spots shall be filled with non seeded Boxers randomly by the computerized draw system.

DIAGRAM 1

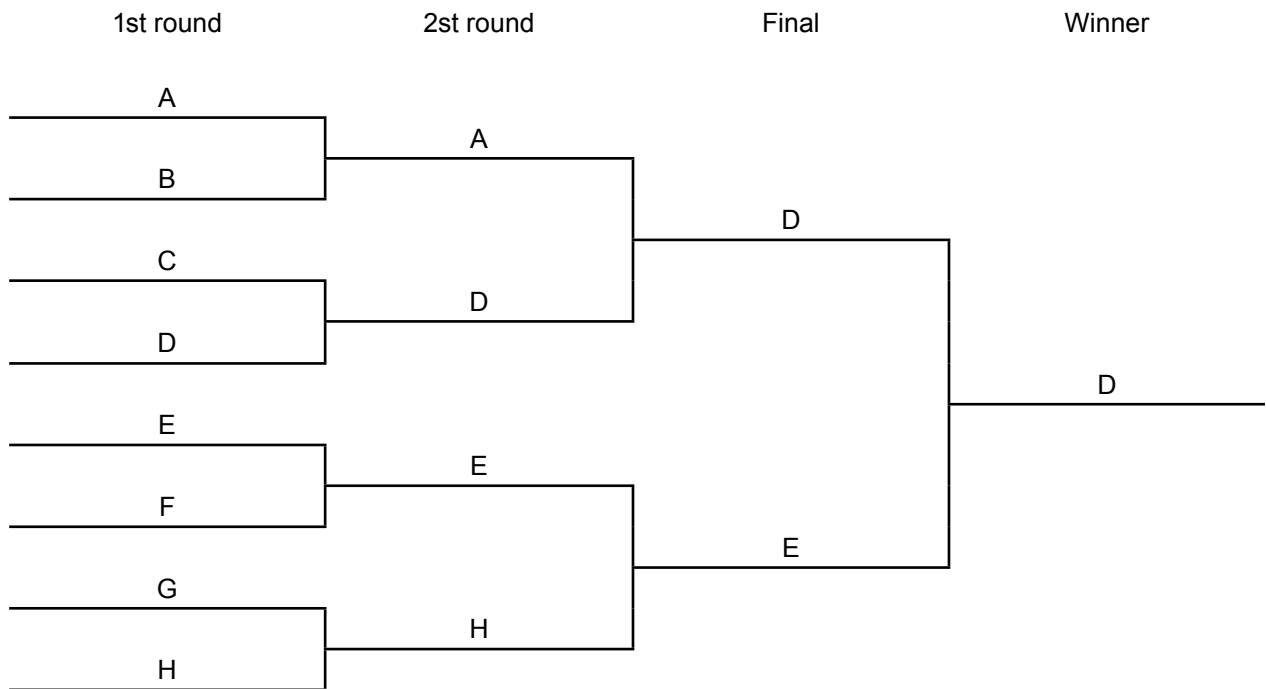

DIAGRAM 2

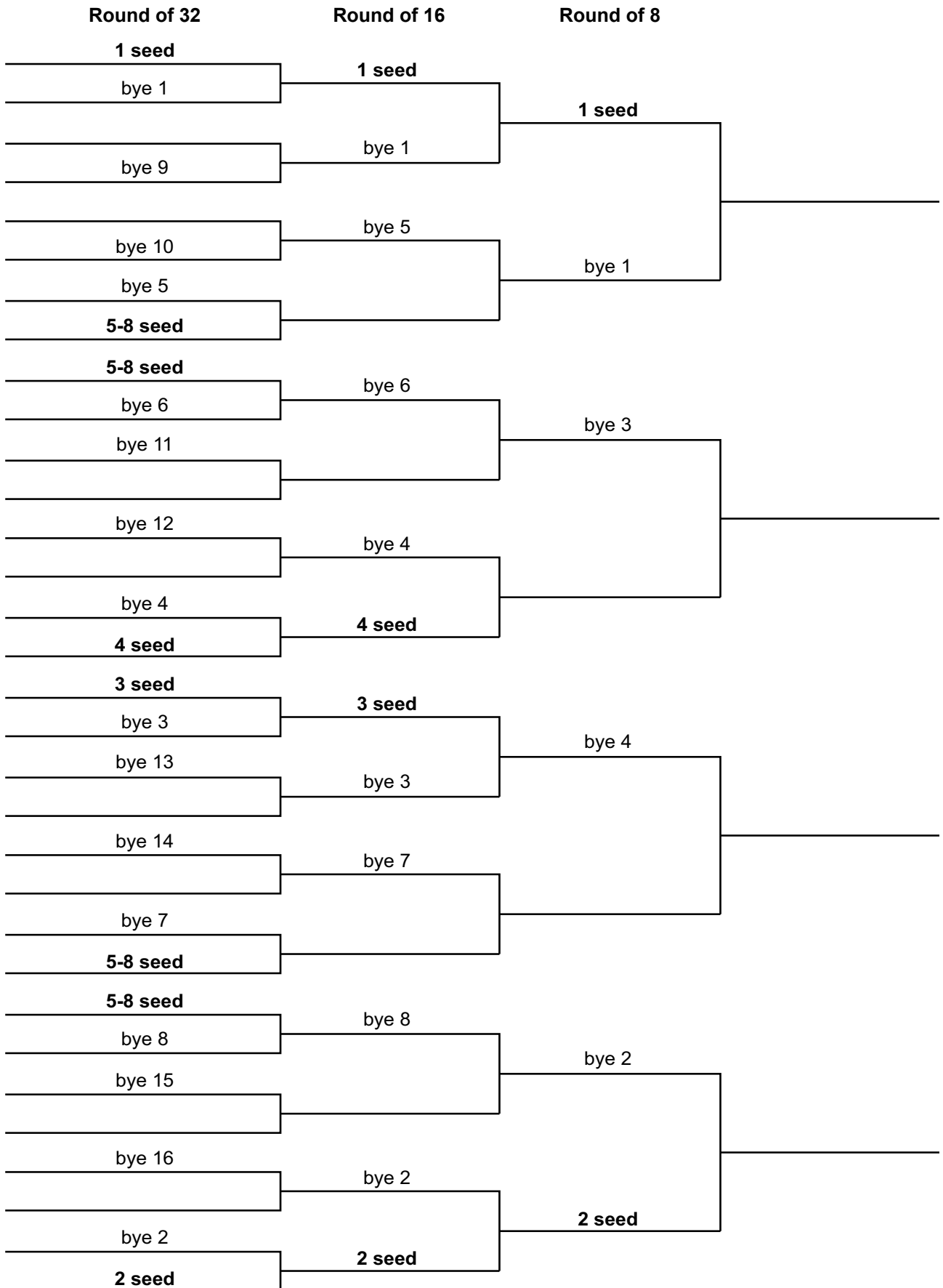

DIAGRAM 3

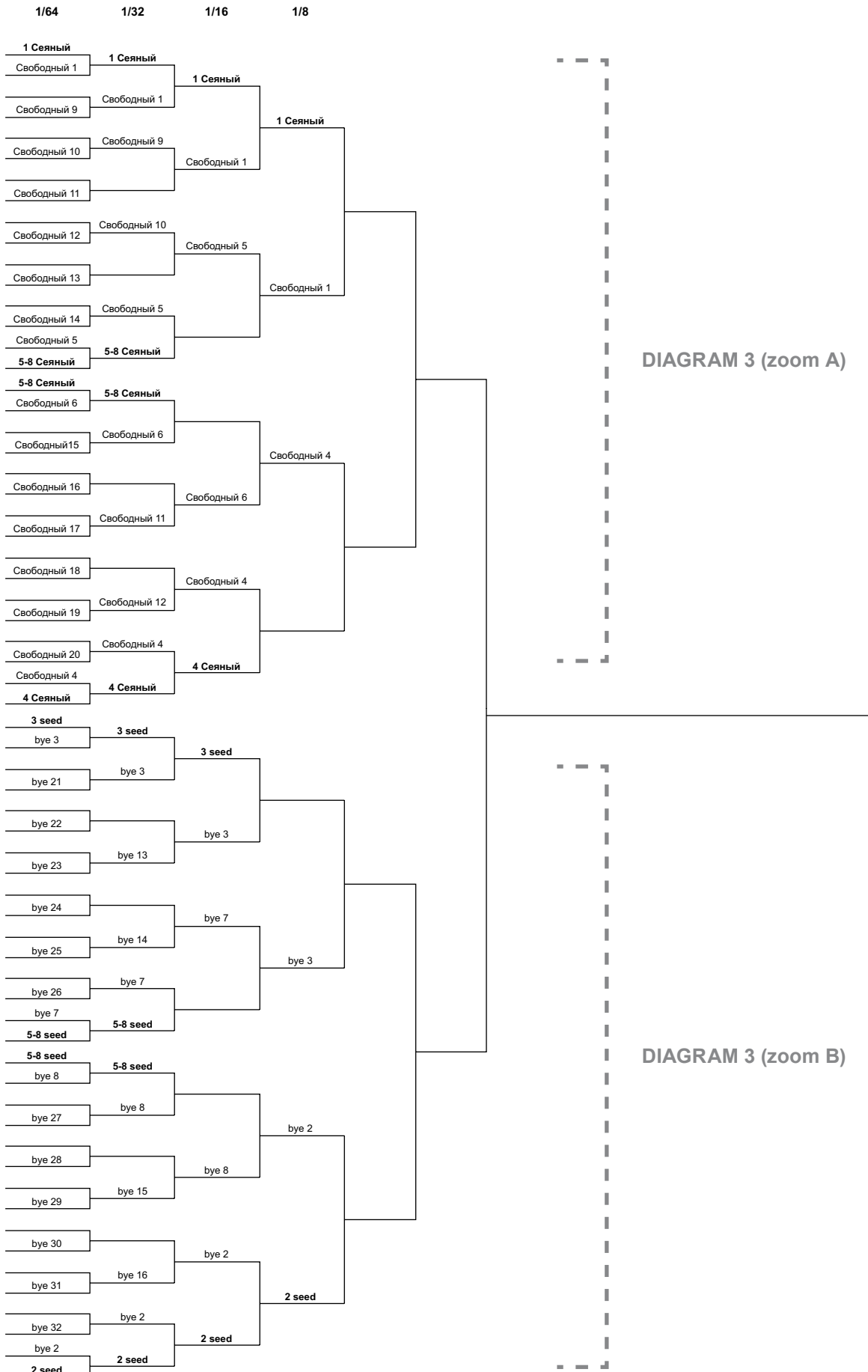

DIAGRAM 3 (zoom A)

DIAGRAM 3 (zoom B)

DIAGRAM 3 (zoom A)



DIAGRAM 3 (zoom B)



APPENDIX F

BOXER'S UNIFORM GUIDELINES

1. VEST AND SHORT SPECIFICATIONS

1.1. National Flag:

- 1.1.1. The flag of the National Federation may be displayed only once on the vest and once on the shorts.
- 1.1.2. The flag must not contain any manufacturer identification, sponsor advertising, design features or other elements.
- 1.1.3. The flag may be printed, embroidered or sewn on as a badge.
- 1.1.4. There are no restrictions on the shape of the flag, but the following measurements and positioning on the kit item must be observed:
 - 1.1.4.1. Vest: Maximum 50cm² (fifty square centimeters) front of the vest, at heart level and side.
 - 1.1.4.2. Shorts: Maximum 50cm² (fifty square centimeters) front of left leg.

1.2. Manufacturers Logo:

- 1.2.1. The manufacturer identification may be printed, embroidered or sewn on to the vest and must not interfere with the other elements identifying the National Federation (e.g. flag). The following quantities, positioning and measurements must be observed:
 - 1.2.1.1. Vest:
 - The logo identification is permitted to be positioned once on the front of the vest at chest level on the right area
 - Maximum 20cm² (twenty square centimeters).
 - 1.2.1.2. Shorts:
 - The logo identification is permitted once to be positioned at the front of right leg.
 - Maximum 20cm² (twenty square centimeters).

1.3. National Olympic Abbreviation of the National Federation

- 1.3.1. The National Olympic Abbreviation of the National Federation may be displayed only once on the back of the vest.
- 1.3.2. The letters used for the National Olympic Abbreviation of the National Federation must not exceed 10cm (ten centimeters) in height.
- 1.3.3. The letters used for the National Olympic Abbreviation of the National Federation must be in a contrasting color to the colors of the vest. For better legibility, they may be affixed to a neutral colored patch or surrounded by a border or shadow outline.
- 1.3.4. The National Olympic Abbreviation of the National Federation must not interfere with the other elements of the kit identifying the Boxer (e.g. Boxer's name).

1.4. Boxer's Name:

- 1.4.1. Each Boxer may be identified by means of surname or popular name on the back of the vest. The name must be identical to that indicated in the passport.
- 1.4.2. The name must be positioned on the upper part of the back of the vest between the shoulder blades area. The letters used for the name must not exceed 5cm (five centimeters) in height and the name width should not exceed 20cm (twenty centimeters).
- 1.4.3. The letters used for the name must be in a contrasting color to the colors of the vest. For better legibility, they may be affixed to a neutral colored patch or surrounded by a border or shadow outline.
- 1.4.4. They may not contain any manufacturer identification, sponsor advertising, design features or other elements.

1.5. National Federation Sponsors Advertising:

- 1.5.1. All forms of advertising for sponsors or third parties, of political, religious or personal statements or other prohibited class such as alcohol (exception for beer and wine), tobacco, casino, gambling and betting are prohibited on all kit items inside the venue.
- 1.5.2. The National Federation sponsor advertising may be printed, embroidered or sewn on to the vest and must not interfere with the other elements identifying the National Federation (e.g. the flag). The following quantities, positioning and measurements must be observed:
 - 1.5.2.1. Vest:
 - The sponsor advertising is permitted once to be positioned on the front of the vest below the chest level area
 - Maximum 150cm² (one hundred fifty square centimeters).

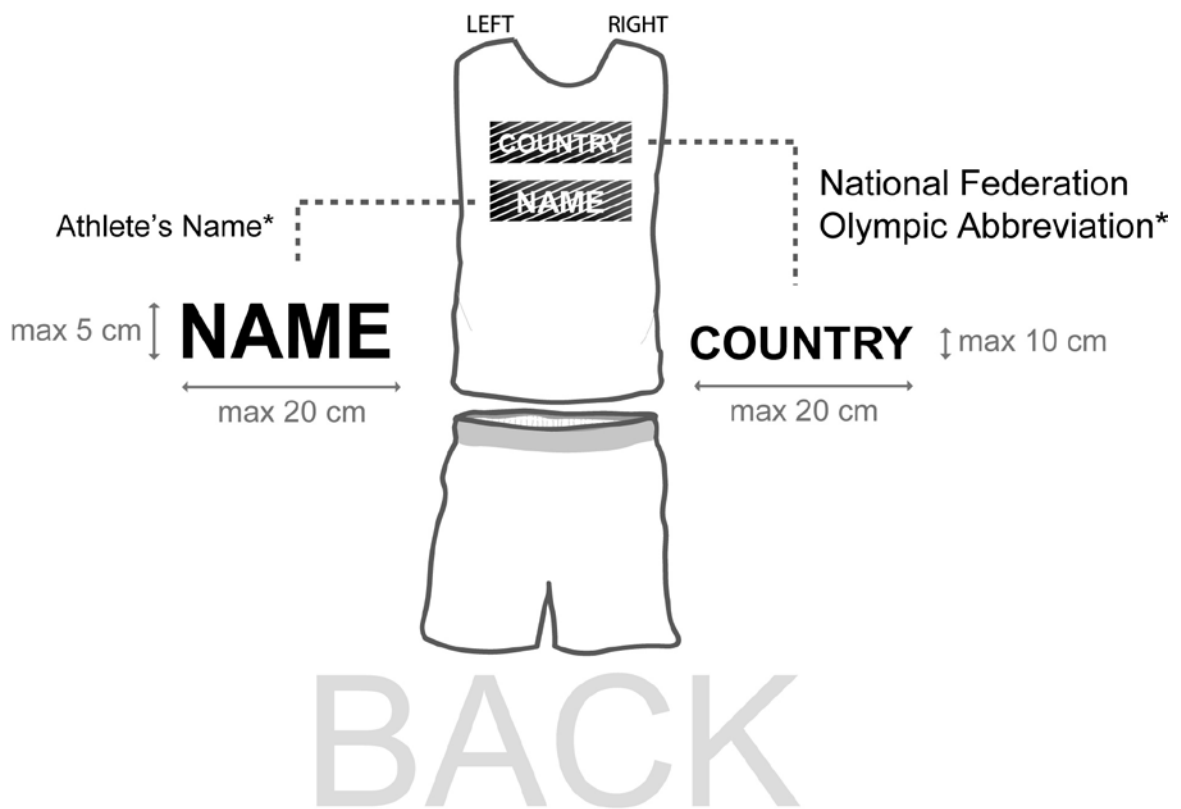
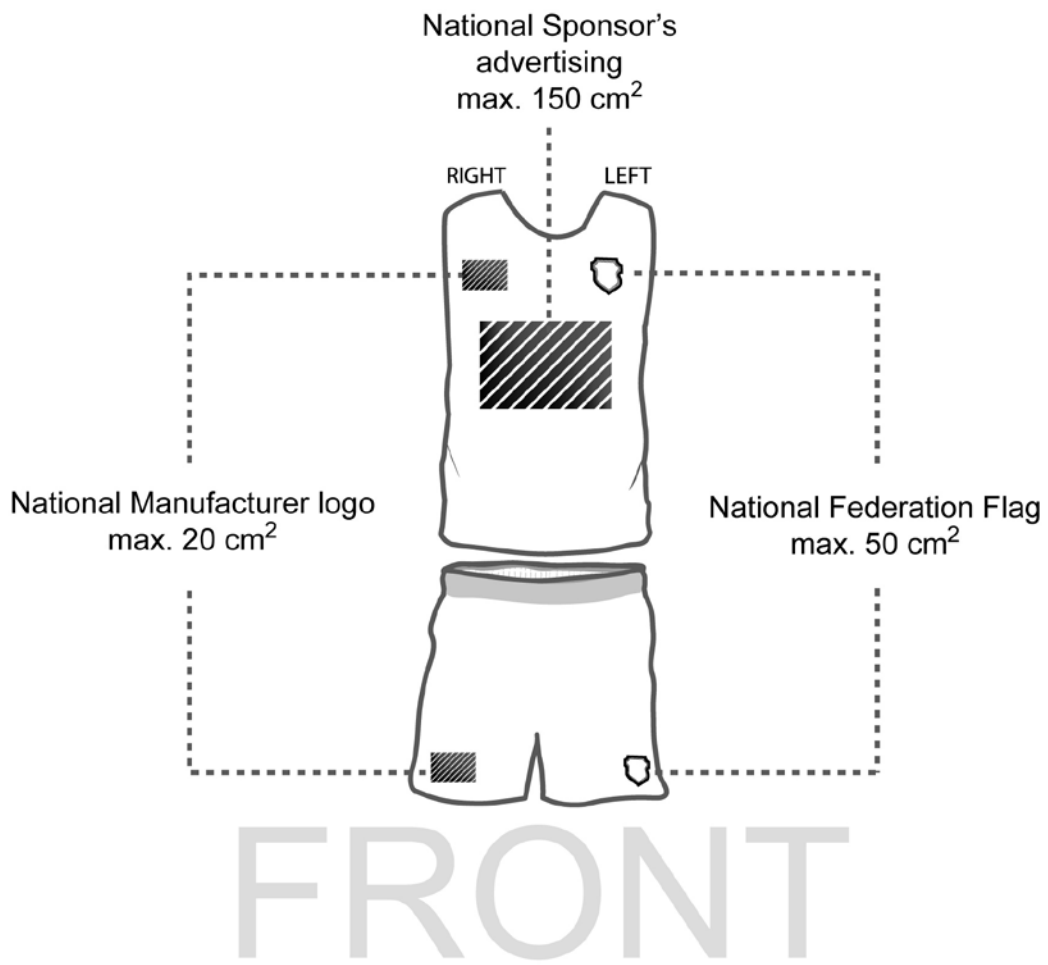

APPENDIX G

AIBA REFEREES & JUDGES MANAGEMENT SYSTEM

1. R&J QUALIFICATION MANAGEMENT

1.1. Standard criteria to meet AIBA R&J Fundamental Qualifications:

1.1.1. Social Status - The following persons cannot be active R&Js:

- 1.1.1.1. All elected members who are Executives of National Federations such as Presidents, EC members, Secretary Generals, etc.
- 1.1.1.2. Any paid employees of National Federations.
- 1.1.1.3. Active team managers, coaches, trainers, etc.
- 1.1.1.4. Refereeing & Judging Commission, Technical & Rules Commission and Women Commission members.

1.1.2. Sport Status:

- 1.1.2.1. The R&Js in the World Series of Boxing can be active R&Js in AIBA and vice versa.
- 1.1.2.2. A person cannot be a Referee only but can be a Judge only.
- 1.1.2.3. Persons from a non-boxing background or former Boxers may become R&Js.

1.1.3. Physical Status:

- 1.1.3.1. All color-blind persons cannot be R&Js.
- 1.1.3.2. A deaf person cannot be a Referee

1.1.4. Ethical Status:

- 1.1.4.1. Any R&J suspended by AIBA for ethical reasons will no longer be accepted for any activity within boxing.

2. R&J QUALITY ENHANCEMENT MANAGEMENT

- 2.1. All R&Js in any level should be trained and judge the competitions only by following the AIBA R&J manual.
- 2.2. AIBA certifies the R&J Instructors to provide the educational seminars and training courses in national and regional levels.
- 2.3. Only AIBA certified R&Js are allowed to officiate in any boxing competitions and should be registered in the AIBA's database.

3. R&J CERTIFICATION / CLASSIFICATION MANAGEMENT

3.1. R&J Tests:

- 3.1.1. New examination criteria to be developed
- 3.1.2. Written examination
- 3.1.3. Oral examination (given a scenario, evaluate language level)
- 3.1.4. Practical live examination
- 3.1.5. Reaction test
- 3.1.6. Physical test, eye sight (color-blindness)
- 3.1.7. Aptitude test
- 3.1.8. Referee & Judge exams separately

3.2. Paths to be AIBA R&Js:

3.2.1. Module 1

- 3.2.1.1. The candidate should be given the introductory booklet two to three weeks before the Induction Examination. This booklet covers the rules the candidate should know to begin the first stage.
- 3.2.1.2. The induction process should commence with a four hour clinic, 2 x 2 hour sessions, covering all the topics in the exam paper and conducted by the National Federation's certified R&J trainer.
- 3.2.1.3. On successful completion of the induction period and the examination paper, the candidate will have demonstrated sufficient knowledge of the rules to advance to Module 2.
- 3.2.1.4. AIBA Officials Induction Clinic – Judges

The purpose of the session is to prepare the candidates to become qualified National Level Judges and to familiarize them with and have them understand the rules that will help them providing athletes with fair and consistent rulings.

3.2.2. Module 2

- 3.2.2.1. The candidate should be assigned to a "mentor" (an already qualified AIBA official in good standing) who will supervise progress throughout Module 2.
- 3.2.2.2. The first stage is to spend at least ten contests working with a certified Timekeeper; five as the Assistant Timekeeper then five as the Timekeeper under the supervision of the certified Timekeeper.
- 3.2.2.3. This complete module gains practical experience of the three areas required to work in or around the ring thus refereeing, judging and an appreciation of timekeeping.
- 3.2.2.4. The second stage will see the candidate introduced to actual contests as a "Supernumerary Judge" using either the AIBA Scoring System or a hand held scoring machine or clicker device.
- 3.2.2.5. The candidate should score at least 30 contests under the supervision and critique of the candidate's mentor.
- 3.2.2.6. Having completed the above, the candidate will, with the approval of the candidate's mentor, advance to the next Module.

3.2.3. Module 3

- 3.2.3.1. This stage will necessitate some practice as a Referee in gymnasium sparring sessions.
- 3.2.3.2. This can usually be arranged in a number of ways, such as:
 - In sessions arranged by the National Federation
 - In a facility arranged and approved by the candidate's mentor
 - In a boxing club to which the candidate is registered.
- 3.2.3.3. When the candidate is considered as being ready, the candidate should be introduced as a Referee in junior contests and complete successfully at least 30 bouts, again under the management and critique of the candidate's mentor.
- 3.2.3.4. During this time, the candidate will also undoubtedly have completed numerous bouts as a Judge and, on the recommendation of the candidate's mentor, should then be approved to National Level.

3.2.4. Module 4 - National Level

- 3.2.4.1. National level is where the candidate can operate at all levels within the Federation and should accomplish the following recommended minimum parameters:
 - Judge 50 contests
 - Referee 30 contests
 - Both of the above should include at least one National Elite Championships.
- 3.2.4.2. When all of the above has been completed with an acceptable level of competency, the candidate can be recommended by the National Federation's R&J Trainer for the AIBA Entrance Examination.

3.2.5. Module 5 - National Level

- 3.2.5.1. Candidates for admission to the lists of AIBA Referees & Judges cannot be Executive members or paid employees of National Federations
- 3.2.5.2. The AIBA Entrance Examination can be arranged by the candidate's National Federation or the candidate can attend an examination being hosted by another National Federation or quite possibly at the AIBA Boxing Academy.
- 3.2.5.3. The AIBA Entrance Examination will consist of four parts:
 - An extensive questionnaire examination paper covering AIBA Technical & Competition Rules
 - An oral examination to clarify that the candidate understands these rules
 - Judge at least ten contests in a competition
 - Referee at least five contests in a competition
- 3.2.5.4. The Candidate must demonstrate total competency in all the segments of the examination to be accredited as an AIBA 1 Star R&J. Should the candidate demonstrate an exceptional talent to the examiners during the examination, the candidate could be invited to attend a course at the AIBA Boxing Academy which, if completed to a very high standard, could fast track the candidate to AIBA 3 Star R&J status.

3.2.5.5. Eligibility:

- Challenge Matches
- Designated Multi-Nations Tournaments (for 2 Star Assessment).

3.2.6. Module 6 - AIBA 2 Star R&J

3.2.6.1. Eligibility:

- All Multi-Nations Tournaments
- Designated Multi-Nations Tournament (for 3 Star Workshop Assessment).

3.2.7. Module 7 - AIBA 3 Star R&J

3.2.7.1. As this is the highest grade an AIBA R&J can obtain, it is awarded to only the very best Officials who have continually demonstrated their high standards in judging and refereeing and successfully completed to a high degree of competency the AIBA Boxing Academy's Workshop / Examination.

3.2.7.2. Eligibility:

1. Olympic Games, Youth Olympic Games, Olympic Qualifying Events
2. All AIBA World Championships
3. Commonwealth Games, Asian Games, Pan-American Games, African Games
4. Confederation Championships
5. World Cup
6. President's Cup
7. Approved Multi-Sports Games

3.2.7.3. AIBA R&J 2 and 3 Star status is performance maintained and any lowering of standards or questionable performance by the holder may result in a recommended downgrade.

3.2.7.4. It is also possible that an AIBA R&J who is considered incompetent may have the AIBA R&J status revoked completely.

3.2.7.5. AIBA R&Js and indeed all members of the AIBA Family are expected to conduct themselves in a manner that will never bring AIBA into disrepute.

3.3. R&J Test Procedure

3.3.1. 1 Star Test

3.3.1.1. When a National Federation determines to test members for admission to the lists of AIBA 1 Star R&Js, it should adopt the following procedure:

- Make application to the AIBA HQs Office along with give full details of tournament, venue, dates, etc.
- Complete the Test Application Form for each candidate and forward to the AIBA HQs Office
- Transfer the appropriate test fees (US\$ 100 per applicant) to AIBA's bank account
- The AIBA HQs Office will forward exam request to the AIBA R&J Commission

- Commission will appoint the Exam Commission consisting of two members:
 - o A member from the R&J Commission from a different continent than the examinees
 - o An AIBA Boxing Academy Instructor
- Exam Commission will inform the AIBA HQs Office of the exam's results
- The AIBA HQs Office will relay results to AIBA R&J Commission and the National Federation and forward all appropriate certificates, record books, badges, etc., to candidates.

3.3.2. Graduation to 2 Star

3.3.2.1. The AIBA R&J Commission, with the approval of the AIBA Executive Committee, will designate Multi-Nations Tournaments in all continents where 1 Star R&Js can be assessed for promotion to 2 Star status using the following procedure:

- All National Federations will be informed of the tournaments where R&J Commission appointed personnel will be present to assess 1 Star R&Js for graduation to 2 Star status
- The Assessor, in collaboration with the Jury members present at these tournaments, will make and forward Upgrade Recommendations to the AIBA HQs Office which will further forward to the AIBA R&J Commission
- When a 1 Star R&J has had four of the aforementioned recommendations, promotion can be considered for to 2 Star status
- The AIBA R&J Commission Evaluation Panel will review all recommendations and approve the warranted upgrades on a bi-annual basis.

3.3.3. Graduation to 3 Star

3.3.3.1. 3 Star is the highest ranking of AIBA R&Js and therefore this status will only be granted to the very best Officials and be limited in numbers

3.3.3.2. Once granted, the maintenance of this standard is performance based and any lapse in standards of the Officials will almost certainly result in demotion

3.3.3.3. To ensure that AIBA will always have sufficient numbers of 3 Star R&Js, Graduation Workshops will be staged at the AIBA Boxing Academy on a bi-annual basis

3.3.3.4. When a 2 Star AIBA R&J has obtained the 3 Upgrade Recommendations from the Assessors at the designated tournaments, then application can be made for a place at the AIBA Boxing Academy's 3 Star Graduation Workshop

3.3.3.5. National Federations will be informed of the designated tournaments

3.3.3.6. A panel will review all applications for admission to the Graduation Workshop and select from the lists the highest rated candidates to fill the twenty places that will be available on each course

3.3.3.7. The Graduation Workshops will be conducted by the AIBA Boxing Academy Instructors and suitably qualified members of the AIBA R&J Commission and will consist of a three day workshop followed by two days of examination

3.3.3.8. Only the very best candidates will qualify and those who fail will remain as 2 Star and will need to obtain a further 3 Upgrade Recommendations before then can apply for another Graduation Workshop at the AIBA Boxing Academy.

3.4. Validity of Test Period

- 3.4.1. The AIBA R&J certification is valid for a period of four years from commencement and after that period, the Official or respective National Federation must arrange for a control test.
- 3.4.2. Should an R&J officiate successfully at a major AIBA Championships, Olympic Games, etc., then the validity period of the license will be extended to four years from the date of that tournament.

4. R&J APPOINTMENT MANAGEMENT FOR COMPETITIONS

- 4.1. For all AIBA major events, the AIBA R&J Commission will prepare a list of suitably qualified officials and present the names to the AIBA President for his approval.
- 4.2. For all Confederation Events, the Confederation R&J Commission will prepare a list of suitably qualified officials and present the names to the Confederation President for his approval.
- 4.3. For major events, a Captain of R&Js should be nominated
 - 4.3.1. To be the leader in the R&J group
 - 4.3.2. To be the spokesperson of the R&J group
 - 4.3.3. To be the chaperon / liaison person for the R&J group
- 4.4. Whenever AIBA is responsible for R&J costs, it should cover the following
 - 4.4.1. Complete travel costs
 - 4.4.2. Accommodation / meals
 - 4.4.3. Visa fee
 - 4.4.4. Per diem
 - 4.4.5. Certification diploma and evaluation (but not if suspended or removed).
- 4.5. Approved Events to be covered by AIBA
 - 4.5.1. Olympic Qualifying Events
 - 4.5.2. All AIBA World Championships
 - 4.5.3. Confederation Championships
 - 4.5.4. World Cup
 - 4.5.5. President's Cup

5. R&J PERFORMANCE MANAGEMENT – R&J EVALUATION

- 5.1. R&Js will be evaluated in every events by
 - 5.1.1. Developing a new computerized evaluation system (together with new scoring system)
 - 5.1.2. In addition to the computer evaluation, Competition Jury members shall give a separate evaluation based on AIBA evaluation criterias
- 5.2. Evaluation of Referees & Judges separately
- 5.3. Based on the evaluation in each day, the Technical Delegate shall have the right to release or suspend R&Js clearly from their duties.

6. R&J IN-COMPETITION MANAGEMENT

- 6.1. Unification of R&Js before the start of each international event by the organization of a mandatory one full day seminar conducted by a designated AIBA R&J Instructor.
- 6.2. R&J Meeting / Assessments
 - 6.2.1. Each day, the contest sheet of the previous day should be displayed by the Chairperson of the Jury at least 10 minutes before the start of the R&J meeting and mistakes should be highlighted
 - 6.2.2. R&Js should not be able to take the contest sheets
 - 6.2.3. The R&J meeting should be conducted by the Chairperson of the Jury - for AIBA events, the Chairman or a member of the R&J Commission shall conduct the meeting.
 - 6.2.4. For other events, the R&J meeting should be conducted by the Technical Delegate.
 - 6.2.5. Under no circumstances will the Technical Delegate endorse an R&J Record Book with an opinion of performance at a tournament – The Technical Delegate shall specify the number of bouts officiated by each R&J.
 - 6.2.6. The computer Judges Evaluation and Competition Juries' Evaluation will be forwarded to the AIBA HQs Office along with the Referee Assessment Forms and the AIBA HQs Office will maintain performances records.
- 6.3. The R&J Lounge
 - 6.3.1. The R&J lounge and meeting room should be comfortable, have proper chairs and tables and should be clean.
 - 6.3.2. The lounge should be checked and approved by the Technical Delegate before the event to satisfy the requirements.
- 6.4. Hotel Accommodation
 - 6.4.1. The R&J hotel accommodation should be separate from Delegations but could be the same as the AIBA Family and ITOs.
- 6.5. Accreditation – access zone definition
 - 6.5.1. R&Js should only get access to the Field Of Play and R&J Lounge.
- 6.6. Dress Code
 - 6.6.1. All R&Js in AIBA Approved Events shall wear uniforms provided by AIBA.
- 6.7. Code of Conduct
 - 6.7.1. AIBA R&J Code of Conduct should be signed at all events by participated R&Js.

7. R&J DATABASE MANAGEMENT

7.1. AIBA R&J Database Maintenance

7.1.1. The AIBA HQs Office maintains all records of R&Js on their participation, evaluation and personal information.

7.1.2. Except the performance evaluation, all information shall be available to the public.

7.2. AIBA Commission Members

7.2.1. Membership to AIBA and Confederation R&J Commissions is restricted to persons who were active on the AIBA R&J lists with a 3 Star status.

7.2.2. Membership to the AIBA R&J Commission is further restricted to candidates who have served at least two years on their Confederation R&J Commission.

7.2.3. Active AIBA R&Js cannot serve on any R&J Commissions.

7.2.4. Confederation R&J Commission Chairpersons to be part of the AIBA R&J Commission.

7.2.5. All applicants must have the support of their respective National Federation.

7.2.6. All applications for membership to the AIBA or Confederation R&J Commissions should be submitted to the AIBA or Confederation HQs Office at least three months before the respective Congress.

8. WSB R&J MANAGEMENT

8.1. Eligibility

8.1.1. Only AIBA 3 Star R&Js shall be able to apply to be a WSB R&J.

8.1.2. No R&J having officiated as R&J in professional boxing is eligible.

8.2. WSB R&J Selection

8.2.1. AIBA R&J Commission approves the selection and dispatch the R&Js for to WSB R&J Certification Program which is managed by WSB

APPENDIX H

RING SPECIFICATIONS AND GUIDELINES

1. THE RING AND ACCESSORIES

1.1. Canvas Size

- 1.1.1. For all AIBA Approved Events, the competition ring shall be 6.10m squared (20 feet) inside the line of the ropes.
- 1.1.2. For all other competitions, the minimum size of the inside of the ropes shall be 4.90m squared (16 feet) and the maximum size – 6.10m squared (20 feet).
- 1.1.3. The size of the apron shall extend for 85cm (33.5 inches) outside the line of the ropes on each side for all AIBA Approved Events and at least 46cm (18 inches) outside the line of the ropes on each side for all other competitions, including additional canvas necessary to tighten and secure it.

1.2. Height of Ring

- 1.2.1. For all AIBA Approved Events, the height of the ring should be 100cm (3.3 feet) from the ground.
- 1.2.2. For all other competitions, the competition ring shall not be less than 91cm (3 feet) or more than 1.22m (4 feet) above the ground or base.

1.3. Platform and Corner Pads

- 1.3.1. The platform shall be safely constructed, leveled and free from any obstructing projections.
- 1.3.2. For all AIBA Approved Events, the platform shall be 7.80m squared (25.6 feet)
- 1.3.3. For all other competitions, the minimum size of the platform shall be 5.82m squared (19.1 feet) and the maximum size – 7.80m squared (25.6 feet)
- 1.3.4. It shall be fitted with four corner posts which shall be well padded or otherwise constructed so as to prevent injury to the Boxers.
- 1.3.5. The corner pads should be arranged in the following way: In the near left-side corner facing the Chairperson of the Jury - red; in the far left side corner - white; in the far right-side corner - blue; and in the near right-side corner - white.

1.4. Surface of the Ring Floor

- 1.4.1. The floor shall be covered with felt, rubber or other suitably approved material having the same quality of elasticity and not less than 1.3cm (half an inch) nor more than 1.9cm (three quarters of an inch) thick over which a canvas shall be stretched and secured in place.
- 1.4.2. The canvas shall cover the entire platform and shall be made of non-slippery material.

1.5. Ropes

- 1.5.1. All AIBA Approved Events should have 4 separate ropes on each side of the ring. They should be 4cm thick, without considering the cover.
- 1.5.2. The heights of the four (4) ropes shall be 40.6cm (16 inches), 71.1cm (28 inches), 101.6cm (40 inches) and 132.1cm (52 inches) from the canvas.

- 1.5.3. The four ropes shall be joined on each side of the ring, at equal intervals, by two pieces of material (close to the texture of the canvas) 3 to 4cm (1.2-1.6 inches) wide. The two pieces must not slide along the rope.
- 1.5.4. The tension of each section of the rope shall be strong enough to absorb the impact of the Boxer's contact with the rope. However, in any case, the Referee reserves the right to adjust the tension if necessary.
- 1.6. Steps
 - 1.6.1. The ring shall be provided with three sets of steps. Two sets of steps at the opposite corners for the use of the Boxers and seconds, and one set of steps in the neutral corner for the use of the Referees and Doctors.
- 1.7. Sanitary Bags
 - 1.7.1. In the two neutral corners outside of the ring, a small plastic bag shall be fixed in each corner in which the Medical Jury, Doctors or Referees shall drop the cotton or tissue pads used to nurse bleedings.
- 1.8. Approved Label
 - 1.8.1. For all AIBA Approved Events, the Organizing Committee should use the rings manufactured by one of the AIBA Official Licensees.
 - 1.8.2. All existing rings can be used until 2010. However, after 2010, for all AIBA Approved Events, a new ring with AIBA approved labels must be used.

2. ACCESSORIES OF THE RINGSIDE

- 2.1. The following are defined as the accessories of the ringside which are required for all AIBA Approved Events:
 - 2.1.1. Gong (with striker) or bell. In the case of two (2) competition rings, one ring is to have a gong and the other ring is to have a bell with two distinctive sounds.
 - 2.1.2. Two seats for Boxers' use during intervals.
 - 2.1.3. Two plastic mugs can to be used for drinking and mouth wash only, and where water is not piped directly to the ringside, two plastic spray bottles and two small plastic bottles for drinking. No other type of water bottle is permitted at ringside for use by the Boxers or seconds.
 - 2.1.4. Tables and chairs for officials.
 - 2.1.5. One (preferably two) stop watches.
 - 2.1.6. One first-aid kit.
 - 2.1.7. One microphone connected to the loudspeaker system.
 - 2.1.8. Two (2) pairs of competition gloves (one in red and one in blue color).
 - 2.1.9. One stretcher.
 - 2.1.10. Two (2) headguards (one in red and one in blue color).

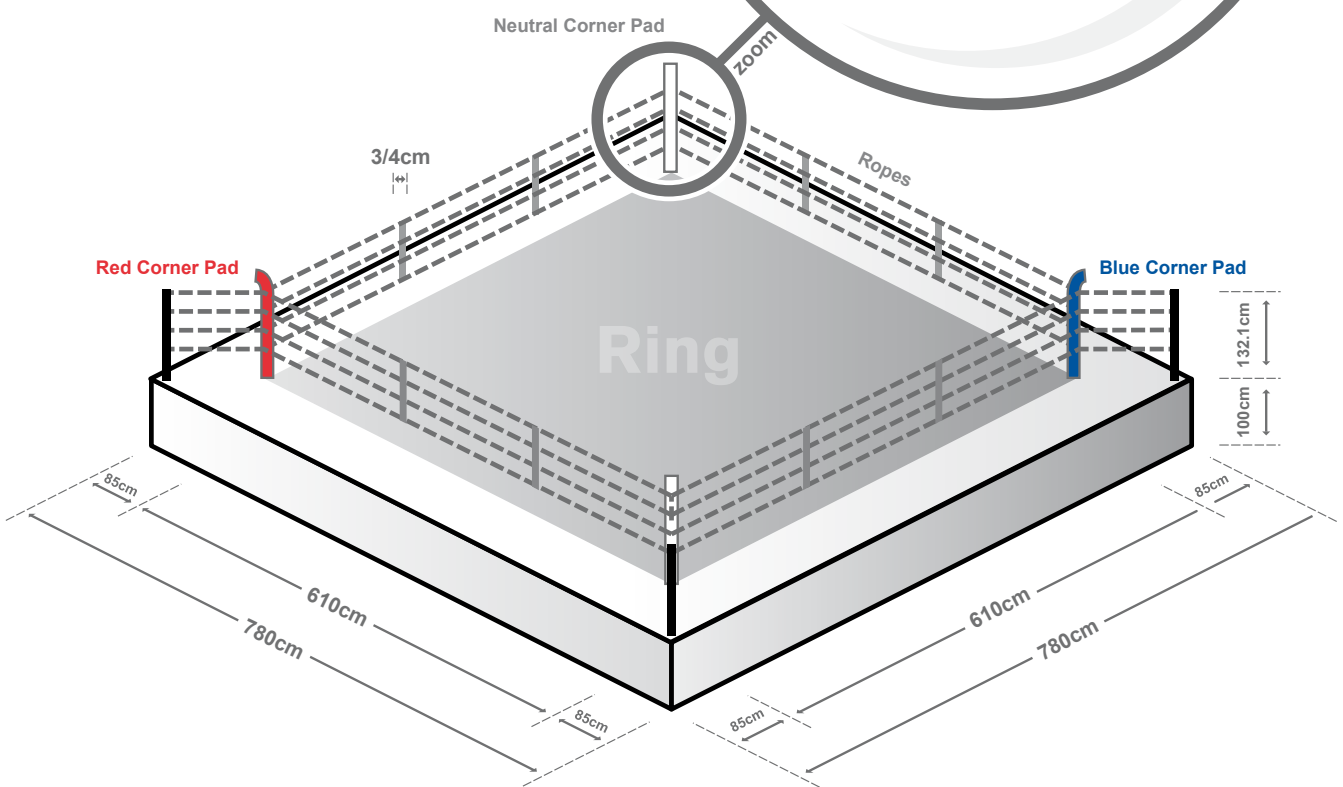
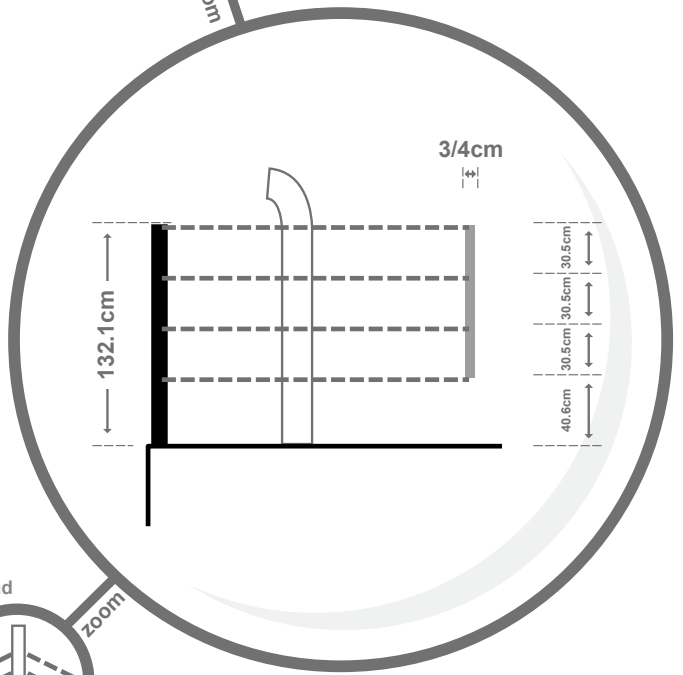
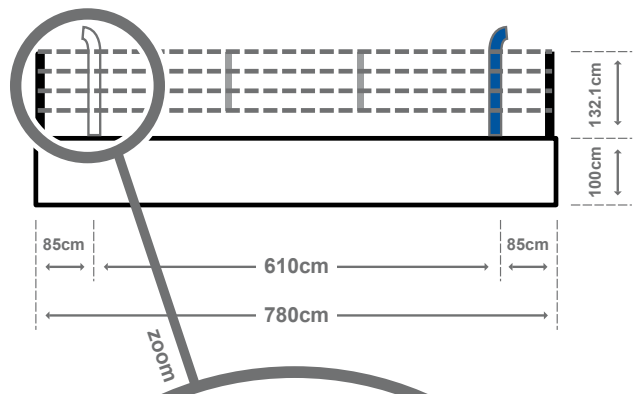
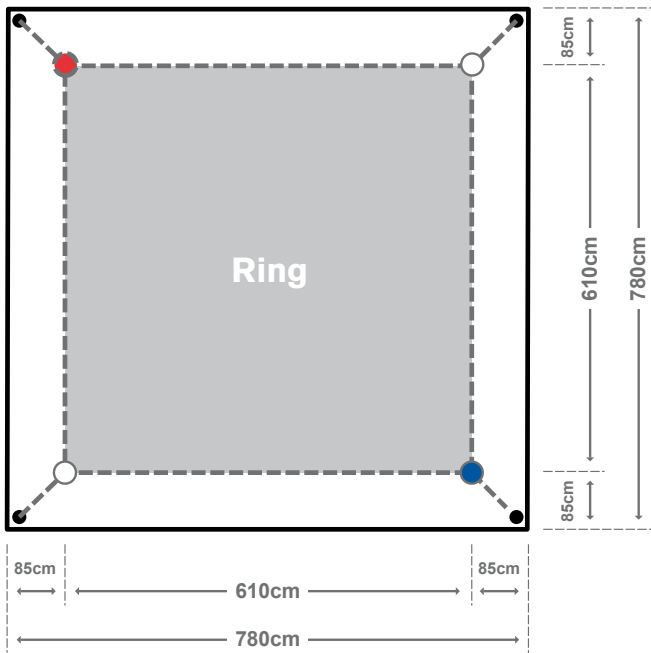

APPENDIX I FIELD OF PLAY

1. FOP FORMATION OF ONE RING

1.1. FOP Formation of one ring:

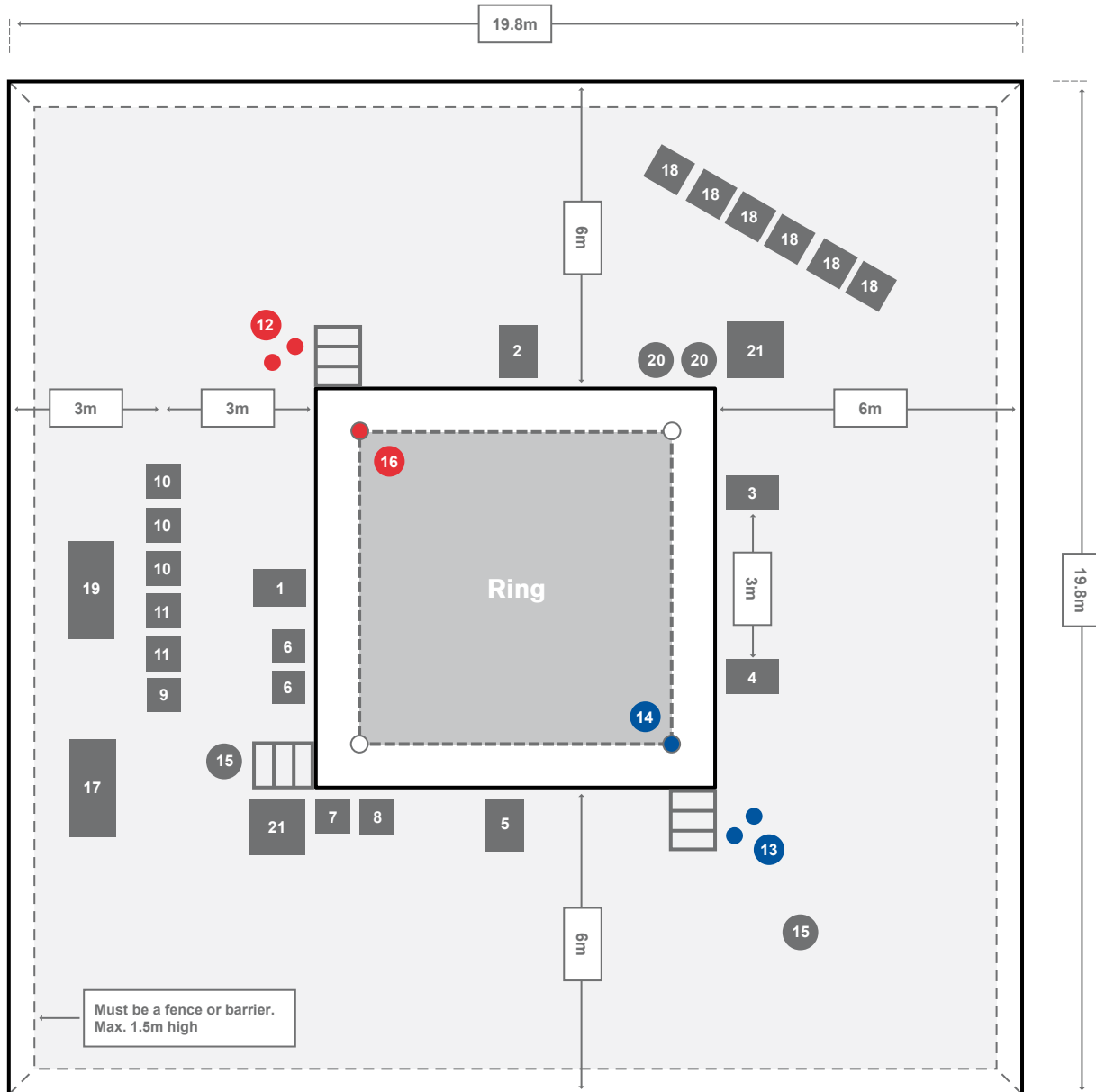

1. Judge Position #1
2. Judge Position #2
3. Judge Position #3
4. Judge Position #4
5. Judge Position #5
6. Medical Jury Table
7. Time Keeper
8. Gong
9. Announcer
10. Head Jury
11. Scoring System Operator

12. Red Corner Seconds
13. Blue Corner Seconds
14. Blue Corner
15. Neutral Corner
16. Red Corner
17. Technical Delegates Table
18. Referee & Judges on Call
19. Draw Jury
20. Photographers
21. Camera/Television Stand (if necessary)

2. FOP FORMATION OF TWO RINGS

2.1. FOP Formation of two rings:

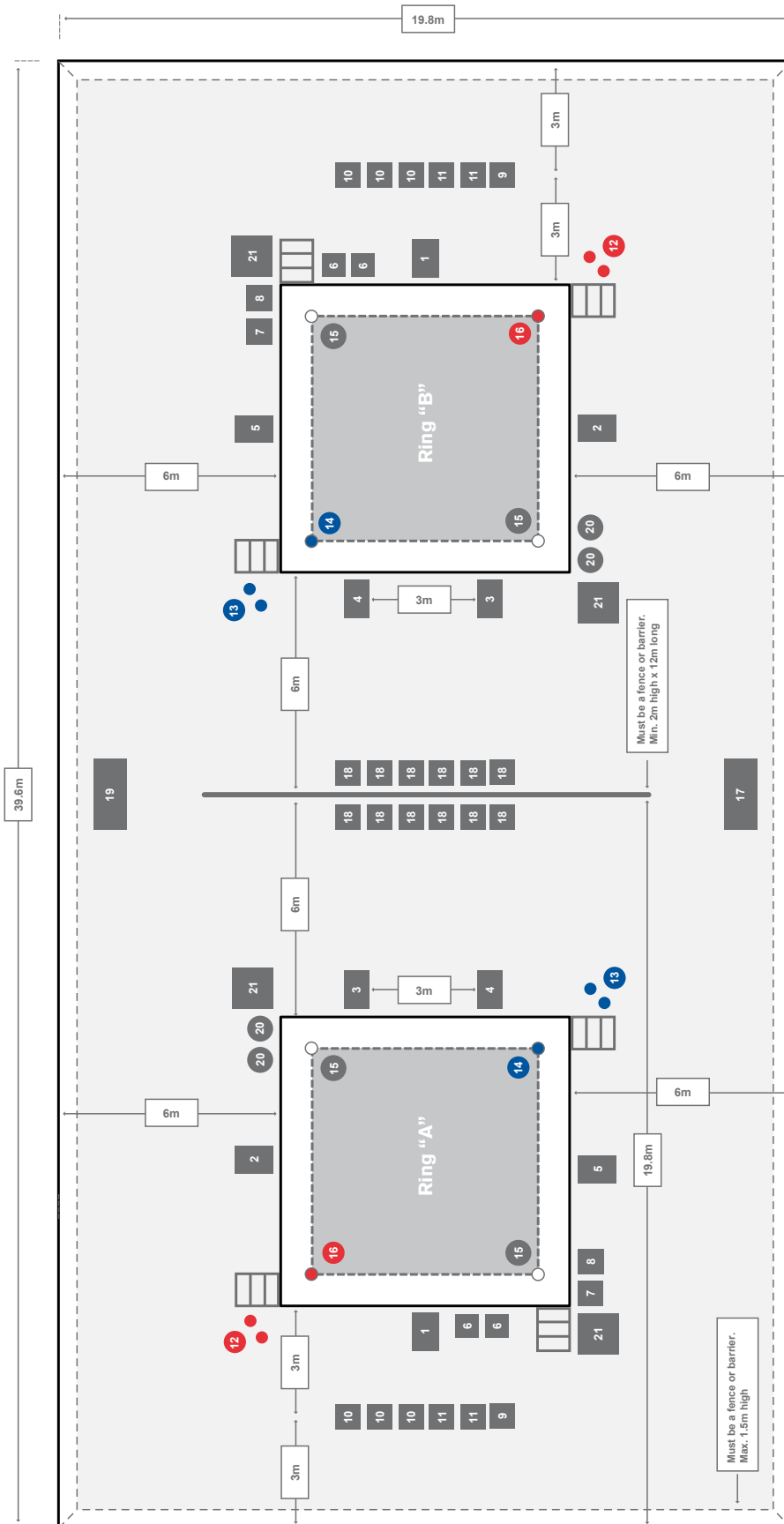

1. Judge Position #1
2. Judge Position #2
3. Judge Position #3
4. Judge Position #4
5. Judge Position #5
6. Medical Jury Table
7. Time Keeper
8. Gong
9. Announcer
10. Head Jury
11. Scoring System Operator

12. Red Corner Seconds
13. Blue Corner Seconds
14. Blue Corner
15. Neutral Corner
16. Red Corner
17. Technical Delegates Table
18. Referee & Judges on Call
19. Draw Jury
20. Photographers
21. Camera/Television Stand
(if necessary)

APPENDIX J

GLOVES AND HEADGUARD SPECIFICATIONS AND GUIDELINES

1. Boxing Gloves

- 1.1. The boxing gloves shall weigh 10 ounces (284 grams), with a tolerance of 5% up or downwards, of which the leather portion shall not weigh more than half of the total weight, and the padding portion shall not weigh less than half of the total weight. The margin of 5% would also apply downwards and upwards, respectively.
- 1.2. The size of the boxing glove shall respect the measurements as described in the graphic below.
- 1.3. Only boxing gloves with Velcro closing systems shall be approved to AIBA Approved Events.
- 1.4. The leather portion of the boxing gloves shall be made of high quality leather such as
 - 1.4.1. Cowhide leather
 - 1.4.2. Grad A leather
 - 1.4.3. Others of equivalent quality subject to AIBA approval.
- 1.5. The thumb should be fixed to the main body of the boxing gloves by the top part and with a maximum gap of 10 millimeters
- 1.6. The event identification may be printed and may be displayed at the following positioning and measurements:
 - 1.6.1. Maximum 50cm² (fifty square centimeters) on the front top part of each glove.
- 1.7. The official supplier's logo may be printed and may be displayed at the following positioning and measurements:
 - 1.7.1. Maximum 50cm² (fifty square centimeters) on the wrist of each glove.
- 1.8. Any other form of advertising shall be prohibited such as and non limited to figurative logo, design mark, script and manufacturer name, etc.

2. HEADGUARD

- 2.1. The Headguard shall weigh a maximum of 450 grams.
- 2.2. The Headguard shall be allowed in competition in 3 mandatory sizes (S=Small, M=Medium, L=Large).
- 2.3. Only headguards with Velcro closing systems shall be approved to AIBA Approved Events.
- 2.4. The measurements of the headguard shall respect the dimension as described in the graphic below.
- 2.5. The padding of the headguard shall respect a minimum thickness of 2cm to 3,5cm
- 2.6. The leather portion of the headguards shall be made of high quality leather such as:
 - 2.6.1. Cowhide leather

- 2.6.2. Grad A leather
- 2.6.3. Others of equivalent quality subject to AIBA approval.
- 2.7. The event identification may be printed and may be displayed at the following positioning and measurements:
 - 2.7.1. Maximum 50cm² (fifty square centimeters) on the front part of the head guard.
- 2.8. The official supplier's logo may be printed and may be displayed at the following positioning and measurements:
 - 2.8.1. Maximum 40cm² (fifty square centimeters) on the wrist of each glove.
- 2.9. Any other form of advertising shall be prohibited such as and non limited to figurative logo, design mark, script, manufacturer name, etc.

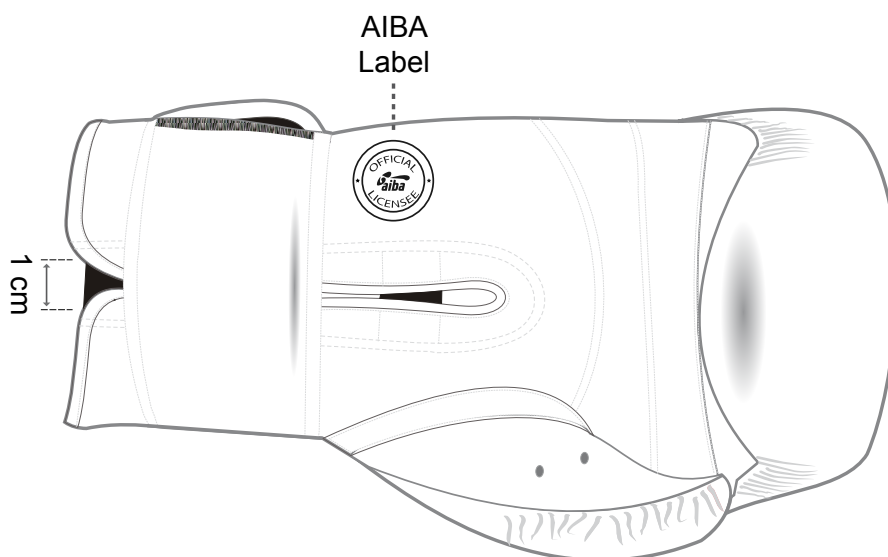
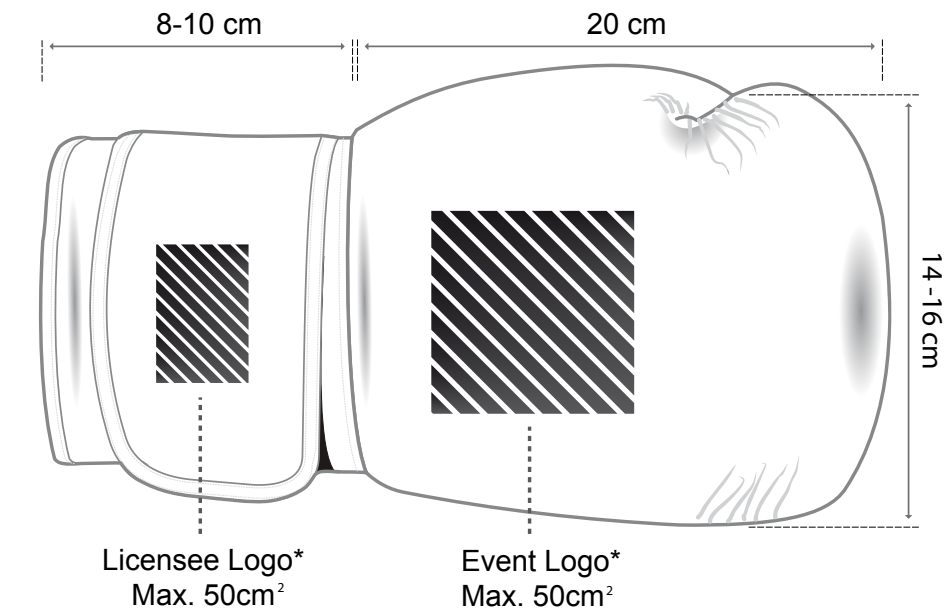

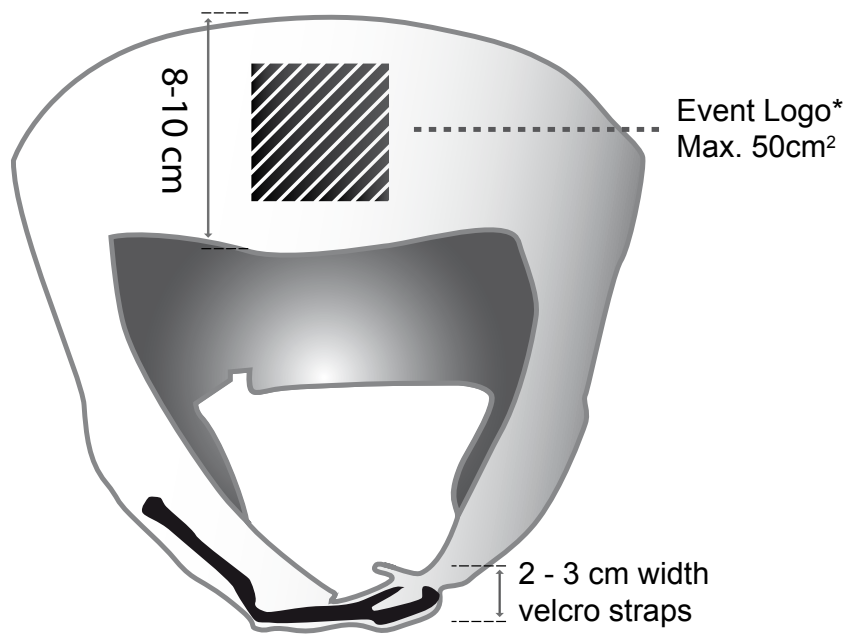

FRONT

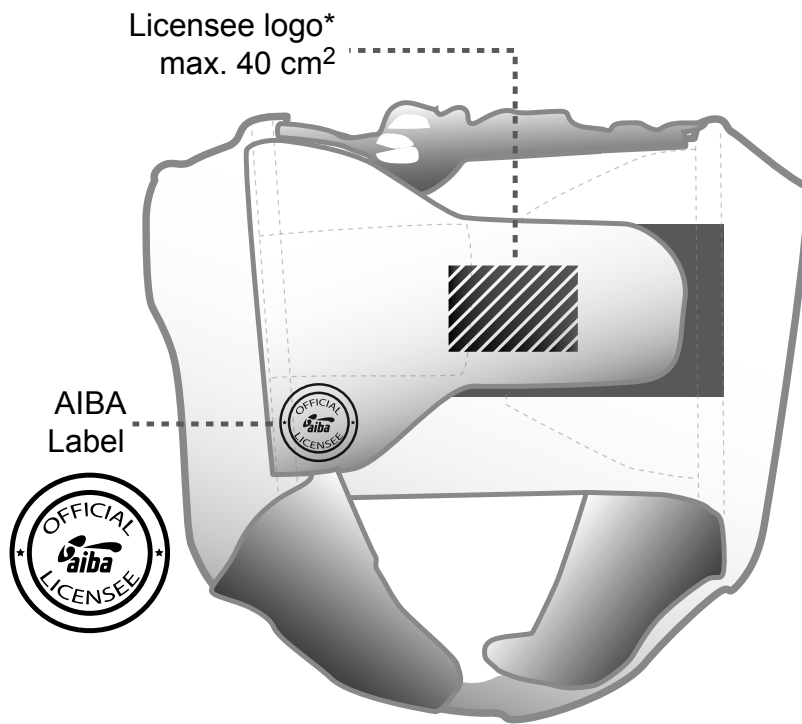

BACK

APPENDIX K

TERMINOLOGY FOR WEIGHT CATEGORIES AND WEIGHT RANGE

Elite Men and Youth Boy Boxers 10 Weight Categories (from September 1, 2010)		
Weight Category	over kg	to Kg
Light Fly	46	49
Fly	49	52
Bantam	52	56
Light	56	60
Light Welter	60	64
Welter	64	69
Middle	69	75
Light Heavy	75	81
Heavy	81	91
Super Heavy	91	-

Olympic Games Elite Women and Youth Girls Boxers 3 Weight Categories		
Weight Category	over kg	to Kg
Fly	48	51
Light Welter	57	60
Light Heavy	69	75

Elite Women and Youth Girls Boxers 10 Weight Categories (from September 1, 2010)		
Weight Category	over kg	to Kg
Light Fly	45	48
Fly	48	51
Bantam	51	54
Feather	54	57
Light	57	60
Light Welter	60	64
Welter	64	69
Middle	69	75
Light Heavy	75	81
Heavy	81	-

Junior Boys and Junior Girls Boxers 13 Weight Categories		
Weight Category	over kg	to Kg
Pin	-	46
Light Fly	46	48
Fly	48	50
Light Bantam	50	52
Bantam	52	54
Feather	54	57
Light	57	60
Light Welter	60	63
Welter	63	66
Light Middle	66	70
Middle	70	75
Light Heavy	75	80
Heavy	80	-